

June 2006

HVAC Design Manual

For

- New Hospitals
- Replacement Hospitals
- Ambulatory Care
- Clinical Additions
- Energy Centers
- Outpatient Clinics

Department of Veterans Affairs
Office of Facilities Management
Facilities Quality Service (181A)
810 Vermont Avenue, N.W.
Washington, D.C. 20420

[CLICK HERE TO
OPEN DOCUMENT](#)



**Department of
Veterans Affairs**

Blank page left intentionally

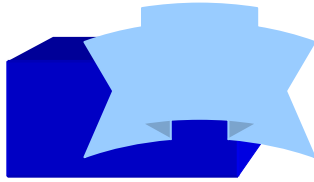

Table of Contents

CHAPTER 1: GENERAL REQUIREMENTS

- 1.1 CRITERIA UNIQUE TO VA
- 1.2 SCOPE OF HVAC DESIGN
- 1.3 BASIC DESIGN PARAMETERS
- 1.4 CONTRACT DRAWINGS
- 1.5 CALCULATIONS, ANALYSIS AND REVIEW SUBMITTALS
- 1.6 HVAC CALCULATIONS FOR HIGHER ELEVATIONS
- 1.7 EQUIPMENT LOCATIONS AND INSTALLATION
- 1.8 LOCATION OF OUTDOORS AIR INTAKE AND EXHAUST AIR OUTLETS
- 1.9 ENERGY CONSERVATION
- 1.10 DESIGN FOR EXISTING BUILDINGS CERTIFICATION OF BUILDING ENERGY PERFORMANCE

CHAPTER 2: HVAC SYSTEMS AND EQUIPMENT

- 2.1 HVAC SYSTEMS SELECTION EQUIPMENT
- 2.2 SPECIAL REQUIREMENTS FOR ALL AIR SYSTEMS
- 2.3 HVAC EQUIPMENT REQUIREMENTS
- 2.4 VARIABLE AIR VOLUME (VAV) SYSTEMS
- 2.5 FAN COIL SYSTEM
- 2.6 RADIANT CEILING PANEL SYSTEMS
- 2.7 HEATING SYSTEMS
- 2.8 ETHYLENE GLYCOL-WATER SYSTEM
- 2.9 STEAM DISTRIBUTION
- 2.10 VENTILATING SYSTEMS
- 2.11 EXHAUST SYSTEMS
- 2.12 REFRIGERATION SYSTEMS FOR AIR-CONDITIONING
- 2.13 SMOKE AND FIRE PROTECTION AUTOMATIC TEMPERATURE CONTROL SYSTEMS
- 2.14 SEISMIC REQUIREMENTS (HVAC) EMERGENCY POWER FOR HVAC

CHAPTER 3: HVAC REQUIREMENTS FOR OCCUPIED AREAS

- 3.1 AMBULATORY CARE-EVALUATION AND EMERGENCY AREA
- 3.2 AMBULANCE ENTRANCES
- 3.3 ANIMAL RESEARCH FACILITY
- 3.4 AUDIO SOUND SUITES
- 3.5 AUDITORIUMS AND THEATERS
- 3.6 BONE MARROW TRANSPLANT (BMT) PATIENT AREAS
- 3.7 CT SCANNERS
- 3.8 COMPUTER ROOMS
- 3.9 DENTAL PROSTHETICS LABORATORY
- 3.10 INTENSIVE CARE UNITS
- 3.11 ISOLATION ROOMS

- 3.12 KITCHENS (MAIN) AND KITCHENS FOR CAFETERIA
- 3.13 LABORATORIES
- 3.14 LAUNDRY (CENTRAL) FACILITY
- 3.15 LINEAR ACCELERATORS
- 3.16 MEDICAL MEDIA SERVICE (MMS)
- 3.17 MAGNETIC RESONANCE IMAGING (MRI)
- 3.18 PSYCHIATRIC AREAS
- 3.19 SHIELDED ROOMS
- 3.20 SUPPLY PROCESSING AND DISTRIBUTION (SPD)
- 3.21 SURGERY SUITES
- 3.22 TB CRITERIA

CHAPTER 4: HVAC REQUIREMENTS FOR UNOCCUPIED AREAS

- 4.1 BATTERY CHARGING AREAS
- 4.2 BIOMEDICAL INSTRUMENT REPAIR SHOP
- 4.3 ELEVATOR MACHINE ROOM
- 4.4 EMERGENCY GENERATOR ROOM
- 4.5 FLAMMABLE AND COMBUSTIBLE LIQUID STORAGE SPACES
- 4.6 REAGENT GRADE WATER TREATMENT ROOMS
- 4.7 RADIOACTIVE IODINE
- 4.8 TELEPHONE EQUIPMENT ROOMS
- 4.9 TRANSFORMER ROOMS (VAULTS) AND ELECTRICAL CLOSETS
- 4.10 TRASH COLLECTION AREAS
- 4.11 WALK-IN REFRIGERATORS AND FREEZERS
- 4.12 XENON GAS

CHAPTER 5: SUPPORT DATA

- 5.1 APPLICABLE DESIGN AND CONSTRUCTION PROCEDURES AND REFERENCE DOCUMENTS INDEX
- 5.2 SCHEDULES OF TABLES FOR CHAPTERS 1-4
- 5.3 SELECTION GUIDE FOR VIBRATION ISOLATORS
- 5.4 CLIMATIC CONDITIONS FOR VA MEDICAL CENTERS

INDEX

Blue indicates links. Chapters or various sections in chapters will open upon clicking of these links.

Blank page left intentionally

CHAPTER 1: GENERAL REQUIREMENTS

- 1.1 CRITERIA UNIQUE TO VA
 - 1.1.1 GENERAL
 - 1.1.2 DRAWINGS
 - 1.1.3 GRAPHIC STANDARDS
 - 1.1.4 CLIMATIC CONDITIONS
 - 1.1.5 DUCTWORK/PIPING
 - 1.1.6 ENGINEERING ECONOMIC ANALYSIS
 - 1.1.7 ENERGY CONSERVATION CERTIFICATE
- 1.2 SCOPE OF HVAC DESIGN
 - 1.2.1 GENERAL
 - 1.2.2 DRAWING REFERENCES
 - 1.2.3 INTERDISCIPLINE COORDINATION
- 1.3 BASIC DESIGN PARAMETERS
 - 1.3.1 CLIMATIC CRITERIA
 - 1.3.2 INDIVIDUAL ROOM TEMPERATURE CONTROLS
 - 1.3.3 INDOOR DESIGN CONDITIONS
 - 1.3.4 SUPPLY AIR REQUIREMENTS
 - 1.3.5 OUTDOOR AIR REQUIREMENTS
 - 1.3.6 EXHAUST AIR REQUIREMENTS (MECHANICAL COOLING)
 - 1.3.7 AIR PRESSURE RELATIONSHIP
 - 1.3.8 NON-AIR CONDITIONED AREAS
 - 1.3.9 ENTRANCES
 - 1.3.10 EXTERIOR STAIRS
 - 1.3.11 CONNECTING CORRIDORS HVAC
 - 1.3.12 NOISE CRITERIA
 - 1.3.13 VIBRATION CRITERIA
 - 1.3.14 SEISMIC BRACING CRITERIA
 - 1.3.15 HVAC EQUIPMENT SIZING CRITERIA
- 1.4 CONTRACT DRAWINGS
 - 1.4.1 GENERAL
 - 1.4.2 SPECIFIC REQUIREMENTS
 - 1.4.3 EQUIPMENT SCHEDULES
 - 1.4.4 PIPING DRAWINGS
 - 1.4.5 DUCTWORK DRAWINGS
- 1.5 CALCULATIONS, ANALYSIS AND REVIEW SUBMITTAL
 - 1.5.1 CALCULATIONS
 - 1.5.2 ECONOMIC ANALYSIS
 - 1.5.3 REVIEW SUBMITTALS
- 1.6 HVAC CALCULATIONS FOR HIGHER ELEVATIONS
 - 1.6.1 GENERAL
 - 1.6.2 DENSITY RATIO
 - 1.6.3 DENSITY CORRECTIONS
- 1.7 EQUIPMENT LOCATIONS AND INSTALLATION
 - 1.7.1 GENERAL
 - 1.7.2 HVAC EQUIPMENT
 - 1.7.3 COORDINATION
 - 1.7.4 COOLING TOWERS
 - 1.7.5 AIR COMPRESSORS
 - 1.7.6 SCREENS AND FILTERS FOR AIR INLETS

- 1.8 LOCATIONS OF OUTDOOR AIR INTAKES AND EXHAUST AIR OUTLETS
 - 1.8.1 GENERAL
 - 1.8.2 MINIMUM REQUIREMENTS
 - 1.8.3 SPECIAL REQUIREMENTS
 - 1.8.4 TYPE OF LOUVERS
- 1.9 ENERGY CONSERVATION
 - 1.9.1 GENERAL
 - 1.9.2 BUILDING THERMAL ENVELOPE
 - 1.9.3 DESIGN FEATURES
 - 1.9.4 THERMAL STORAGE AND MAJOR CONSERVATION SYSTEMS
- 1.10 DESIGN FOR EXISTING BUILDINGS
 - 1.10.1 GENERAL
 - 1.10.2 EXISTING SURGERY UNIT
 - 1.10.3 HVAC SYSTEM UPGRADE
- 1.11 CERTIFICATION OF BUILDING ENERGY PERFORMANCE

Blank page left intentionally

1 GENERAL REQUIREMENTS

1.1 CRITERIA UNIQUE TO VA

1.1.1 GENERAL

This manual is presented as general guidance. It is for mechanical engineers and others in the design and renovation of facilities for the Department of Veterans Affairs (VA). In order to provide the latitude needed for design, new concepts, etc., deviations may be made from the technical requirements provided professional judgment is made that a safe, adequate, hospital quality level design will result, and approval is obtained from the VA. Deviations from those requirements included in Public Laws, Federal Regulations, Executive Orders, and similar regulations and users special requirements are not permitted. This manual contains some, but not all, of the criteria pertinent to the design of HVAC systems for VA hospitals. Where VA Criteria is lacking or missing, follow industry standards such as ASHRAE, ARI, NFPA, etc.

1.1.2 DRAWINGS

The following information shall be shown on "MH" drawings:

1.1.2.1 HVAC system design including indoor steam piping and walk-in refrigerators/freezers. See [Article 1.2](#) for additional information.

1.1.2.2 Seismic design related to the HVAC systems.

1.1.2.3 Outdoor exposed or underground chilled water piping.

1.1.3 GRAPHIC STANDARDS

The HVAC system design documentation shall use the VA standard symbols, abbreviations, standard details, and equipment schedules. See [Article 1.4](#) for specific requirements.

1.1.4 CLIMATIC CONDITIONS

The outdoor climatic conditions shall be based on the requirements outlined in [Article 1.3](#) and information provided in [Article 5.4](#). These conditions are based on weather data listed in the ASHRAE Handbook of Fundamentals for weather stations, which are located at or near the VA medical centers. The local professional engineers may recommend more severe outdoor climatic conditions, commonly used by them, for review and approval by the VA.

1.1.5 DUCTWORK/PIPING

In the final design drawings (Construction Documents Phase), all ductwork, regardless of sizes and/or complexity of layout(s), and piping above 152-mm (6-inch) size shall be clearly shown and identified in double line with all fittings and accessories.

1.1.6 ENGINEERING ECONOMIC ANALYSIS

To comply with Public Law 95-619, engineering economic analysis shall be performed, in accordance with the procedure outlined by the Department of Energy (DOE) in National Institute of Standards and Technology (NIST) Handbook 135 (Life Cycle Cost Federal Energy Management Program), to select the most cost effective HVAC system for the application. See paragraphs 2.5, 2.6 and 2.12 for restrictions on

use of fan coils, radiant panels and DX systems. The additional features of the analysis are:

- (a) For systems comparison, a 20-year life cycle shall be assumed.
- (b) The analysis may be performed by means of available public domain programs, such as, "TRACE", "E-CUBE", and CARRIER E20-II, etc.
- (c) For specific VA requirements relative to the HVAC systems configurations and limitations, see Articles [1.3](#) and [2.1](#).
- (d) Other relevant features are: 7 percent discount factor for future cost and no taxes or insurance in computing annual owning cost.

1.1.7 ENERGY CONSERVATION CERTIFICATE REQUIREMENTS

Energy conservation shall be emphasized in all aspects of building design. The buildings must meet the requirements of DOE regulations, 10 CFR Part 435, "Energy Conservation Voluntary Performance Standards for Commercial and Multi-Family High Rise Residential Buildings; Mandatory for New Federal Buildings." A copy can be requested from the VA. These standards are mandatory for all new VA facilities. To demonstrate compliance with these regulations, it will be necessary for the A/E to provide the following information:

1.1.7.1 CERTIFICATE OF COMPLIANCE

The A/E shall certify that the Building is designed to be in compliance with the applicable provisions outlined in the DOE regulations identified above. A blank copy of the required certificate is attached in [Article 1.11](#).

1.1.7.2 ESTIMATED ENERGY CONSUMPTION

With the final design submission of construction documents phase, the A/E shall estimate the energy consumption of the proposed new building(s) and provide a value in British Thermal Units (BTUs) per gross square foot (GSF) per year for each building. To accomplish this task, the following shall be done:

- (a) The building(s) operation shall be simulated on the basis of actual mechanical/electrical systems design.
- (b) Use any of the public domain computer programs listed in paragraph 1.1.6(b) to calculate the estimated energy consumption.

1.2 SCOPE OF HVAC DESIGN

1.2.1 GENERAL

Developing complete, accurate, and coordinated contract drawings and specifications is the primary goal of the design and review effort. Design drawings, specifications and calculations shall agree in all respects and they shall be without errors, omissions or deviations from the established criteria.

1.2.2 DRAWING REFERENCES

In addition to all HVAC work, the "MH" drawings shall include all interior steam and condensate piping, the Engineering Control Center (ECC) layout, and HVAC control diagrams.

(a) Outdoor steam distribution shall be shown on "D" (DISTRIBUTION) drawings.

(b) All boiler plant work shall be shown on "G" (GENERATION) drawings.

(c) Walk-in refrigerators/freezers in dietetic areas and in laboratories shall be shown on "H" drawings.

1.2.3 INTERDISCIPLINE COORDINATION

HVAC design must be coordinated with all other disciplines, such as, Architectural, Structural, Electrical, Plumbing and Site Planning. The following HVAC related work is usually shown by other disciplines:

1.2.3.1 Architectural drawings and specifications show all louvers and attached screens in exterior walls, all flashing for ducts and pipes penetrating roofs and exterior walls, finish and identification, painting walls and ceilings, access panels, chases, furred spaces, door grilles, mechanical equipment rooms and penthouses.

1.2.3.2 Structural drawings and specifications show all concrete and structural steel work, including catwalks, concrete housekeeping pads, lintel supports around openings, and platforms for access to HVAC equipment and supports for cooling towers and other large mechanical equipment.

1.2.3.3 Electrical drawings and specifications show motor starters and disconnects not furnished as part of HVAC equipment, smoke detectors (duct and/or space mounted), all power wiring to HVAC smoke dampers, motors, heating cable, controls for winterizing piping, day tank and oil piping in the emergency generator room, and muffler exhaust pipe for emergency generator.

1.2.3.4 Plumbing provides all domestic water make-up supply and drain outlets, underground oil storage tank(s) and piping for emergency generators.

1.2.3.5 Food service and medical equipment, shown on Architectural drawings, include all controlled temperature rooms in laboratories and all hoods in dietetic areas, laboratories, and research areas.

1.2.3.6 For additional information on steam consumption, connections to equipment and ventilation requirements, see Program Guide, PG-7610.

1.3 BASIC DESIGN PARAMETERS

1.3.1 CLIMATIC CRITERIA

Design Climatic conditions are provided in [Article 5.4](#).

(a) Summer: 0.4 percent design dry bulb and wet bulb - Column 1a.
Winter: 99.6 percent design dry bulb - Column 1b.

(b) Wet bulb design temperature for cooling tower: 0.4 percent - Column 3.

(c) Size pre-heat coils based on Annual Extreme Daily-Mean dry bulb temperature listed in Min. Column.

(d) Provide emergency heat based on 99.6 percent design dry bulb temperature - Column 1b. See [Article 2.16](#), "Emergency Power for HVAC."

1.3.2 INDIVIDUAL ROOM TEMPERATURE CONTROLS. See [Paragraph 2.14.1.9](#).

1.3.3 INDOOR DESIGN CONDITIONS: See Table 1-1 below:

Table 1-1 Indoor Design Conditions

Room or Area	Summer		Winter	
	Db Degrees C (Degrees F)	RH Percent	Db Degrees C (Degrees F)	RH Percent
Animal Research (Animal Rooms)	18 (65)	60 (<u>+5</u>)	29 (85)	30 (<u>+5</u>)
Auditoriums	24 (76)	60	22 (72)	--
AIDS Patient Areas	24 (76)	50	25 (78)	30
Autopsy Suites	24 (76)	60	24 (76)	30
Bathrooms & Toilet Rooms	25 (78)	--	22 (72)	--
Blood Banks	22 (72)	50	22 (72)	30
BMT (Bone Marrow Transplant) Patient Areas	24 (76)	50	25 (78)	30
Computer Rooms	21 (70)	40 (<u>+5</u>)	21 (70)	40 (<u>+5</u>)
CT Scanner	24 (76)	50	25 (78)	30
Dialysis Rooms	25 (78)	50	22 (72)	30
Dining Rooms	25 (78)	50	22 (72)	30
Dry Labs	25 (78)	50	22 (72)	30
Electrical Equipment Rooms	Ventilation Only		10 (50)	--
Elevator Machine Rooms, Electric Drive	36 (94)	--	10 (50)	--
Elevator Machine Rooms, Hydraulic	36 (94)	--	10 (50)	--
Emergency Generator	42 (110)	--	4 (40)	--
Examination Rooms	24 (76)	50	25 (78)	30
Gymnasiums	Ventilation Only		21 (70)	--
ICUs (Coronary, Medical, Surgical)	23-29 (75-85)	30-60	23-29 (75-85)	30-60
Isolation Suites	24 (76)	50	25 (78)	30
Kitchens	27 (82)	60	21 (70)	--
Laboratories	24 (76)	50	22 (72)	30
Laundries	28 (84)	60	19 (68)	-
Linear Accelerators	24 (76)	50	25 (78)	30

Room or Area	Summer		Winter	
	Db Degrees C (Degrees F)	RH Percent	Db Degrees C (Degrees F)	RH Percent
Locker Rooms	25 (78)	50	22 (72)	30
Lounges	25 (78)	50	22 (72)	30
Mechanical Equipment Rooms (MERs)	Ventilation Only		10 (50)	--
Medical Media: See Article 3.16				
Minor O.R.s (Trauma Rooms)	24 (76)	50	25 (78)	30
Motor Vehicle Maintenance/Storage	Ventilation Only		21 (70)	--
MRI Units	24 (76)	50	25 (78)	30
Offices, Conference Rooms	25 (78)	50	22 (72)	30
Operating Rooms (O.R.s)	17-27 (62-80)	45-55	17-27 (62-80)	45-55
Operating Rooms (O.R.s) - Animal	22 (73)	50	22 (73)	50
Patient Rooms	24 (76)	50	25 (78)	30
Pharmacy	22 (72)	50	22 (72)	30
Radiation Therapy	24 (76)	50	25 (78)	30
Recovery Units	23 (75)	50	23 (75)	30
Smoking Area	25 (78)	50	22 (72)	30
SPECIAL PROCEDURE ROOMS*				
▪ Bronchoscopy	24 (76)	50	25 (78)	30
▪ Cardiac Catheterization	17-27 (62-80)	45-55	17-27 (62-80)	45-55
▪ Colonoscopy/EGD	24 (76)	50	25 (78)	30
▪ Cystoscopy	22 (72)	50	25 (78)	50
▪ Endoscopy	24 (76)	50	25 (78)	30
▪ Fluoroscopy	24 (76)	50	25 (78)	30
▪ GI (Gastrointestinal)	24 (76)	50	25 (78)	30
▪ Proctoscopy	24 (76)	50	25 (78)	30
▪ Sigmoidoscopy	24 (76)	50	25 (78)	30
Spinal Cord Injury Units (SCIUs)	22 (72)	50	27 (82)	30
Supply Processing Distribution (SPD)	24 (76)	50	22 (72)	30
▪ Ethylene Oxide (ETO) MERs	Ventilation only			
▪ Steam Sterilizer MERs	Ventilation only			
Telephone Equipment Rooms	19(65)-23(75)	40-60	19(65)-23(75)	40-60

Room or Area	Summer		Winter	
	Db Degrees C (Degrees F)	RH Percent	Db Degrees C (Degrees F)	RH Percent
Therapeutic Pools	26(80)-29(85)	--	29 (85)	--
Transformer Rooms	39 (104)	(Maximum)		
Treatment Rooms	24 (76)	50	25 (78)	30
Warehouses	Ventilation Only		15 (60)	--

***TERMINOLOGY OF SPECIAL PROCEDURE ROOMS:**

- Bronchoscopy: Examination of the bronchi (air passage of the lungs) through a bronchoscope.
- Cardiac Catheterization: Employment of a small catheter through a vein in an arm, leg or neck and into the heart.
- Colonoscopy: Examination of the entire colon with a colonoscope.
- EGD (Esophagogastroduodenoscopy): Endoscopic examination of the esophagus and stomach, and duodenum (small intestine).
- Cystoscopy: Direct visual examination of the urinary tract with a cystoscope.
- Endoscopy: Examination of organs such as the bladder, accessible to observation through an endoscope passed through the mouth.
- Fluoroscopy: Examination of deep structures by means of an X-ray fluoroscope.
- GI (Gastrointestinal): Pertaining to the stomach and intestine.
- Proctoscopy: Inspection of the rectum with a proctoscope.
- Sigmoidoscopy: A rigid or flexible illuminated endoscope for examination of the sigmoid (shaped like the letter 'S' or the letter 'C') colon.

1.3.3.1 Notes on Indoor Design Conditions:

(a) These are design conditions and not operating limits. All thermostats shall be adjustable between 15 to 29 degrees C (60 to 85 degrees F).

(1) The summer indoor design relative humidity shown in Table 1.1 need not be maintained by any humidity control either at the air terminal units or at the air-handling units. These values merely represent the design reference points and, in actual practice, would vary due to the predetermined air quantities and fluctuations in the internal heat loads. However, the winter indoor design relative humidity shown in [Table 1-1](#) shall be maintained by a humidity control either at the air terminal units, or at the air handling unit or both.

- (2) Provide capability to maintain 29 degrees C (85 degrees F) in Dialysis and Chemotherapy rooms all year-round.
- (3) Provide capability to maintain 32 degrees C (90 degrees F) and 35 percent RH in Rheumatoid Arthritis rooms year-round.
- (4) Provide capability to maintain 32 degrees C (90 degrees F) and 95 percent RH in Burn Units.
- (5) All other areas, not specifically mentioned above but scheduled to be mechanically cooled and heated, shall have the summer indoor design conditions of 25 degrees C (78 degrees F) Db and 50 percent RH and winter indoor design conditions of 22 degrees C (72 degrees F) Db and 30 percent RH.
- (6) Depending upon the weather conditions, winter humidification may be deleted from non-patient areas upon a review and an approval by the VA.
- (b) Small electrical closets and telephone closets without the heat producing equipment, such as, transformers and electronic panels with data processing boards need not be heated, cooled or ventilated.
- (c) Small storage rooms, with areas less than 5.6 Sq M (60 Sq Ft), also need not be heated, cooled or ventilated.
- (d) Offices, subsistence storage rooms, and storage for X-ray films and pharmaceuticals located in warehouses shall be mechanically cooled to maintain 25 degrees C (78 degrees F) in summer.
- (e) Supply sufficient air quantity to maintain the space humidity in Therapeutic Pools within the limit of 60 percent RH maximum as specified in the ASHRAE Handbook.
- (f) Bathrooms and toilets do not require individual room temperature control in cooling mode. However, a terminal heating device and the temperature control would be required for congregate baths and the exterior bathrooms/toilets.
- (g) Do not provide any room temperature control for ETO MER, Steam Sterilizer MER and Warehouse for maintaining summer indoors temperatures. Ventilate ETO/Steam Sterilizer MERs by drawing room air from clean areas. Select air volume to limit temperature rise in these MERs to -9 degrees C (15 degrees F) above room temperature. See [Article 3.20](#) for SPD Requirements.
- (h) If elevator machine rooms require lower indoor temperatures for proper functioning of the electronic equipment, mechanical cooling shall be investigated and provided, in accordance with the elevator manufacturer's recommendations. See [Article 2.10.5](#) for additional requirements.

1.3.4 SUPPLY AIR REQUIREMENTS (Mechanical Cooling)

The conditioned air shall be supplied to areas at the minimum air changes/hour noted below in Table 1-2. Air quantities could be more due to cooling loads or exhaust requirements of equipment or hoods.

There are no specified minimum total air changes/hour for spaces other than those listed below.

Table 1-2 Air Changes/Hr; Constant Volume v/s VAV Volume System

Areas	Minimum Design Supply Air Changes/Hr	Constant Volume (CV) or Variable Air Volume (VAV)
Animal Research Areas	15	CV
Ante Rooms	12	See Standard Detail 15900-7 or 15900-7A
Autopsy Suite (All rooms)	12	CV
Corridors	4	VAV
Dark Rooms	10	CV
Dialysis Rooms	6	CV
Dining Room	10	VAV
Examination Rooms	6	VAV
Intensive Care Units (ICUs) (All Types)	8	CV
BMT Special Areas, Patient Rooms, Donor Rooms, Recovery Rooms, Medical Preparation Rooms	18	CV
Isolation Rooms		
▪ Aids Patient Room	15	CV
▪ Burn Unit	15	CV
▪ Leukemia	15	CV
▪ Organ Transplant	12	CV
▪ Tuberculosis	12	CV
Kitchens	10	VAV (See Article 3.12)
Laboratories		
▪ Bacteriology	12	CV
▪ Biochemistry	12	CV
▪ Biosafety	12	CV
▪ Cytology	12	CV
▪ General	12	CV
▪ Histology	12	CV

Areas	Minimum Design Supply Air Changes/Hr	Constant Volume (CV) or Variable Air Volume (VAV)
▪ Nuclear Medicine	12	CV
▪ Pathology	12	CV
▪ Special Chemistry	12	CV
Medical Media See Article 3.16		
Minor Operating Rooms (O.R.s) (Trauma Rooms)	12	CV
Operating Rooms (O.R.s)	15 (Occupied)	8 (Unoccupied)
Patient Rooms	4	VAV
Recovery Rooms	8	CV
SPD	See Article 3.20	CV
Special Procedure Rooms		
▪ Bronchoscopy	12	CV
▪ Cardiac Catheterization	15	CV
▪ Colonoscopy/EGD	6	CV
▪ Cystoscopy	15	CV
▪ Endoscopy	6	CV
▪ Fluoroscopy	6	CV
▪ GI (Gastrointestinal)	10	CV
▪ Proctoscopy	6	CV
▪ Sigmoidoscopy	6	CV
Smoking Area	12 (Occupied) 6(Unoccupied)	CV with two settings
Storage Areas	4	CV
Treatment Room	6	VAV
Waiting Room	6	CV

Notes:

(a) If the intensive care units are equipped with individual toilets for each bed, then each toilet shall be exhausted at the rate of 2.2 Cu M/Min (80 CFM). See [Article 3.10](#).

(b) The VA policy for the AIDS patient rooms is that, during the initial stages of the disease, and with no other complications, the patient can be treated in a normal patient room with no specific requirements for air changes and room pressure relationship. If the

patient develops any additional disease(s), such as, tuberculosis, then confinement of the patient in negative pressure isolation room is necessary and the isolation room criteria for air changes and pressure relationship would apply. And if the patient is vulnerable to infectious disease, a positive pressure isolation room will be necessary. The decision regarding the number, location(s), and type of isolation rooms shall be the responsibility of the VA.

(c) See [Article 3.21](#) for Surgery Suite System for the OR HVAC systems.

(d) The minimum supply air quantities for VAV systems shall not be less than the exhaust air requirements, if any.

(e) The supply air quantity for the corridors could be greater than four air changes per hour if this air is to be used as make-up air for exhaust needs of the adjoining areas, such as Toilets, Janitor Closets, Soiled Utilities Rooms, Locker Rooms, etc.

(f) Provide non-aspirating type supply air diffuser in Isolation Rooms.

1.3.5 OUTDOOR AIR REQUIREMENTS (Mechanical Cooling)

1.3.5.1 100 PERCENT OUTDOOR AIR AREAS:

(a) Animal Research Areas

(b) Autopsy Suites

(c) BMT Patient Areas

(d) Complete SPD Departments (Complete Suite)

(e) Laboratories

(f) Surgery Suites

1.3.5.2 NON-100 PERCENT OUTDOOR AREAS

(a) Base minimum outdoor air, in accordance with ASHRAE Standard 62-1999, and with additional specific requirements as listed in [Table 1-3](#).

(b) For the patient bedrooms, except for Intensive Care Units and offices, any one of the following HVAC systems can be used.

(1) Terminal heating and cooling units, such as fan coil units or radiant ceiling panels.

(2) All air systems with minimum outdoor air quantities noted in Table 1-3. Re-circulation of air will be permitted.

(3) The amount of outdoor air and how it is supplied to the occupied spaces would depend upon the type of HVAC system used.

(c) When the fan coil units or radiant ceiling panels are used, a central ventilation unit supplies conditioned air to the spaces. With this arrangement, the source of outdoor air being external to the principle cooling and heating equipment, it is possible to ensure the

predetermined amount of outdoor air distribution to all the spaces. The amount of outdoor air for ventilation shall be based on any one of the considerations listed in Table 1-3, and the maximum amount, thus, derived shall be used. For the radiant panel cooling system, the manufacturer's recommendation for outdoor air shall also be considered.

Table 1-3 Minimum Outdoor Air Requirements

Rooms	Outdoor Air
Patient Bedrooms	2 Air Changes/Hr, or 10 Air Changes/Hr of Make-up Air for the Adjoining Toilets/Bathrooms, or 0.85 Cu M/Min (30 CFM) Per Patient.
Offices (Private)	1 Air Change/Hr, or 0.56 Cu M/Min (20 CFM) Per Person.
Lounge/Waiting Areas	0.42 Cu M/Min (15 CFM) Per Person.

(d) When an all air system is used, the outdoor air is mixed with the return air at the unit, and since the distribution of the supply air is done on the basis of the cooling load requirements, the spaces with greater cooling requirements will, receive more outdoor air. It is, therefore, very important that the outdoor air is evenly distributed to all the spaces and remain constant under all operating conditions.

(e) Minimum outdoor air shall not be less than 15 percent of the supply air.

1.3.6 EXHAUST AIR REQUIREMENTS/PRESSURE RELATIONSHIP

Minimum exhaust air quantities, along with room pressure, for various areas are listed below in Table 1-4. Exhaust air for some areas is based on air changes/hour.

Table 1-4 Minimum Exhaust Air Requirements/Room Pressure

Areas	Room Pressure	Exhaust Air Air Changes/Hr
Admitting and Waiting Areas	Negative	SA + 15 Percent of SA
Ambulance Entrance	Negative	10
Animal Research	Negative	SA + 15 Percent of SA
Ante Rooms	See Standard Detail 15900-7 or 15900-7A	
Autopsy Suite (All Rooms)	Negative	SA + 15 Percent of SA
Battery Charging Areas	Negative	8
Bathing Facilities	Negative	10
Bathrooms	Negative	10
BMT Patient Areas	Positive	SA - 15 Percent of SA

Areas	Room Pressure	Exhaust Air Air Changes/Hr
Ceramics Rooms (dental Prosthetics Laboratories)	Positive	SA - 15 Percent of SA
Clean and Preparation Rooms (SPD Suites)	Positive	SA - 15 Percent of SA
Clean Rooms (Laundry Facilities)	Positive	SA - 15 Percent of SA
Dark Rooms	Negative	SA + 15 Percent of SA
Detergent Storage	Negative	SA + 15 Percent of SA
Dialysis	Positive	SA - 15 Percent OF SA
Dietetics {See Note (a)}	Negative	SA + 15 Percent of SA
Enema or Hopper Rooms	Negative	15
Examination Rooms (MRI Suites)	Equal	12
Flammable Storage	Negative	0.3 Cu M/Min/0.1 Sq M, 4.2 Cu M/Min Minimum (1.0 CFM/Sq Ft, 150 CFM Minimum)
Gas Storage	Negative	0.3 Cu M/Min/0.1 Sq M, 4.2 Cu M/Min Minimum (1.0 CFM/Sq Ft, 150 CFM Minimum)
Glass and Cage Washing Areas	Negative	See Notes
Instrument Rooms (Sterile)	Positive	SA - 15 Percent of SA
Intensive Care Units (ICUs)	Positive	SA - 15 Percent of SA See Article 3.10
Isolation Rooms (Negative Pressure)	See VA STD Detail 15900-7	SA + 15 Percent of SA (All Articles listed in Table 3-5 and Table 3-6) and paragraph 2.11.6
Isolation Rooms (Positive Pressure)	See VA STD Detail 15900-7A	
▪ Aids Patient Rooms	Positive	SA - 15 Percent of SA
▪ Burn Units	Positive	SA - 15 Percent of SA
▪ Leukemia Patient Rooms	Positive	SA - 15 Percent of SA
▪ Organ Transplant Rooms	Positive	SA - 15 Percent of SA
Janitor Closet (HAC)	Negative	10
Kitchen (See Note b)	Negative	SA + 15 Percent of SA
Laboratories	Negative	SA + 15 Percent of SA See Article 3.13

Areas	Room Pressure	Exhaust Air Air Changes/Hr
Laundry (Central Facility)	Negative	See Article 3.14
Locker Rooms {See Note (c)}	Negative	SA + 15 Percent See Note (c)
Medical Media Service (MMS) See Article 3.16		
Minor Operating Rooms (O.R.s) (Trauma Rooms)	Positive	See Article 3.1.2
Operating Rooms (Surgery Suites)	Positive	See Article 3.21
Oral Surgery and Treatment	Positive	SA - 15 Percent of SA
Radiation Therapy	Negative	SA + 15 Percent of SA
Reagent Grade Water Treatment Rooms	Negative	8
Recovery Rooms	Positive	SA - 15 Percent of SA
Silver Recovery Rooms	Negative	6
Smoking Area	Negative	12
Soiled Dishwashing Rooms	Negative	6
Soiled Linen Rooms	Negative	6
Soiled Utility Rooms	Negative	6
Special Procedure Rooms		
▪ Bronchoscopy	Negative	SA + 15 Percent of SA
▪ Cardiac Catheterization	Positive	SA - 15 Percent of SA
▪ Colonoscopy/EGD	Negative	SA + 15 Percent of SA
▪ Cystoscopy	Positive	SA - 15 Percent of SA
▪ Endoscopy	Negative	SA + 15 Percent of SA
▪ Fluoroscopy	Negative	SA + 15 Percent of SA
▪ GI (Gastrointestinal)	Negative	SA + 15 Percent of SA
▪ Proctoscopy	Negative	SA + 15 Percent of SA
▪ Sigmoidoscopy	Negative	SA + 15 Percent of SA
Sterile Corridors (Surgery Suites) See Article 3.21		
Storage Rooms (Soiled or Dirty)	Negative	SA + 15 Percent of SA
Tissue Culture Rooms	Positive	SA - 15 Percent of SA
Toilets	Negative	10
Treatment Room (Bronchoscopy)	Negative	SA + 15 Percent of SA
Trash Collection Areas	Negative	10
Vestibules	Positive	SA - 15 Percent of SA

Areas	Room Pressure	Exhaust Air Air Changes/Hr
Waiting Rooms	Negative	SA + 15 Percent of SA

Notes:

(a) Exhaust air requirement can be waived and re-circulation air permitted, only if the air circulation is confined to a single functional area.

(b) The exhaust air requirements shall be coordinated with the equipment specifications. Maintain these spaces under negative pressure.

(c) The supply air quantity for the locker rooms shall be the larger of the two values calculated either to meet the cooling load requirements, or the exhaust air requirements, associated with their integral bathrooms and toilets.

(d) For the space to be maintained under negative pressure exhaust 15 percent more air than the supply. For the space to be maintained under positive pressure, exhaust 15 percent less air than the supply air.

(e) In the absence of any specified supply air change/hour (See [Paragraph 1.3.4](#)), the exhaust air shall be calculated from the following considerations, and the maximum value, thus, derived, shall be used:

- (1) Space Heat Gain
- (2) Equipment Exhaust Requirements
- (3) Applicable Codes
- (4) 15 percent of the supply air

(f) Individual toilets and HACs do not require ducted supply air. Use air transferred from the occupied spaces via door grilles and/or undercuts, to exhaust these areas. Do not transfer more than 4.2 Cu M/Min (150 CFM) of air per door undercut.

(g) Public toilets and congregate baths do require ducted supply air up to 8.5 air changes per hour maximum. The balance air should be drawn from the corridors to maintain negative pressure and to ensure exhaust of 10 air changes per hour.

1.3.7 AIR PRESSURE RELATIONSHIP

Provide balance between the supply and exhaust air quantities as noted in [Table 1-4](#).

1.3.7.1 The designer shall ensure that the make-up air required to maintain negative pressure, and the excess air to maintain positive pressure, are available and taken into account in the air balance calculations.

1.3.8 NON-AIR CONDITIONED AREAS

See Article 2.10, VENTILATING SYSTEMS.

1.3.9 ENTRANCES

Use forced air heater at all building entrances in frequent use where ambient temperatures are 4 degrees C (40 degrees F) and below.

1.3.10 EXTERIOR STAIRS

Provide heat in all exterior stairs.

1.3.11 CONNECTING CORRIDOR HVAC

Provide cooling and heating, as approved by the VA, in the connecting corridor between the buildings.

1.3.12 NOISE CRITERIA

See Table 1-5 below:

Table 1-5 Noise Level

Type of Rooms	NC Level
Patient	35
Examination Room, Endoscopy and Bronchoscopy	35
Audio Suites, Audio Speech Pathology	35
Phono/Cardiology	35
Chapels	40
Conference	35
Auditorium, Theaters	40
Operating Rooms (Major and Minor)	35
Offices, Small Private	40
Offices, Large Open	35
Pharmacy	40
Lobbies, Waiting Areas	35
Treatment	40
Corridors, Nurse Stations	40
Bathrooms, Toilets	40
Laboratories	45
SPD, Dining, Food Service/Serving	45
Therapeutic Pools	45
Laundries	50
Gymnasiums, Recreation Rooms	50
X-Rays and General Work Rooms	40
Laundries	50
All Other Occupied Areas	35-40*

* Consultants shall discuss with VA any specific area requiring NC levels outside this range.

1.3.12.1 The above NC values may be increased for unitary equipment within occupied spaces if approved by the VA.

1.3.12.2 Sound level of operating equipment, such as fans, chillers. Cooling towers etc. must be considered in the design of HVAC systems. Use sound attenuators, if required.

1.3.12.3 See Paragraph 1.7.4 for cooling tower noise requirements.

1.3.13 VIBRATION CRITERIA

Refer to VA Master Specification, Section 15200, NOISE AND VIBRATION CONTROL. See [Article 5.3](#).

1.3.14 SEISMIC BRACING CRITERIA

See [Article 2.15](#), Seismic Requirements (HVAC).

1.3.15 HVAC EQUIPMENT SIZING CRITERIA

1.3.15.1 AIR HANDLING EQUIPMENT: To compensate for the duct air leakage and any future space internal heat gain, the equipment must be sized in accordance with the following guidelines:

(a) Load Calculations: Heat gain calculations must be done in accordance with the procedure outlined in the latest ASHRAE Handbook of Fundamentals. The calculations performed either manually or with a computer program shall not include any built-in safety factors.

(b) The calculated supply air shall be the sum of all individual peak room air quantities without any diversity, even for the variable air volume systems.

(c) Safety Margin: A safety factor of 5 percent shall be applied to the calculated room air quantity to allow for any future increase in the room internal load.

(d) The adjusted supply air shall be, thus, 5 percent in excess of the calculated supply air.

(e) Air leakage: The air leakage through the supply air distribution ductwork shall be computed on the basis of the method described in the SMACNA Air Duct Leakage Test Manual. The maximum leakage amount shall not exceed 4 percent of the adjusted supply air.

(f) Supply Air Fan Capacity: The capacity of the supply air fan shall be calculated per the following example:

(1) Calculated Supply Air Volume = 560 Cu M/Min (20,000 CFM)

(2) Safety Margin = 5 percent of item (1) = 28 Cu M/Min (1,000 CFM)

(3) Adjusted Supply Air Volume = 588 Cu M/Min (21,000 CFM)

(4) Duct Air Leakage = 4 percent of item (1) = 24 Cu M/Min (840 CFM)

(5) Supply Air Fan Capacity = 612 Cu M/Min (21,840 CFM)

(g) Equipment Selection: selection of the supply air fan, cooling coil, preheat coil, energy recovery coil (if any), filters, louvers, dampers, etc., shall be based on the supply fan capacity, 612 Cu M/Min (21,840 CFM) calculated in the example above. A psychrometric chart shall be prepared for each air-handling unit. Make sure heat gains due to the fan motor and duct friction losses are taken into account for sizing cooling coils.

(h) Air Distribution:

(1) The main supply air ductwork shall be sized to deliver the supply air fan capacity, 612 Cu M/Min (21,840 CFM) as calculated in the example above.

(2) The individual room air distribution system including supply, return, exhaust air ductwork, air terminal units, reheat coils and air outlets/inlets shall be sized and selected on the basis of the adjusted supply air volume, 588 Cu M/Min (21,000 CFM).

(3) The fan and motor selection shall be based on the supply air fan capacity and static pressure adjusted, as necessary, for the altitude, temperature, fan inlet and discharge conditions, and the AMCA 201 System Effect Factors. The fan selection shall be made within a stable range of operation at an optimum static efficiency. The fan motor W (BHP), required at the operating point on the fan curves, shall be increased by 10 percent for drive losses and field conditions to determine the fan motor horsepower. The fan motor shall be selected within the rated nameplate capacity and without relying upon NEMA Standard Service Factor. See VA Standard Detail 15000-50 for the energy efficient motors.

(g) Motor Voltages:

(1) Motor Voltages shall conform to NEMA/ANSI standard as follows:

Table 1-5 System/Motor Voltages

System Voltage (Transformers)		Utilization Voltage (Motors)
Nominal	With 4 Percent Drop	Standard (For Schedule)
120	115.2	115
208	199.7	200
240	230.4	230
480	460.8	460
600	576.0	575
2400	--	2300
4160	--	4000

1.3.15.2 CHILLED WATER SYSTEMS

(a) The capacity of the chilled water system, which consists of condenser and chilled water pumps, cooling tower, piping, etc. shall be based on the sum of the total cooling requirements of all connected air handling units. See [paragraph 1.3.15.1](#) for the derivation of the total cooling load requirements for air handling units. No additional safety factors should be required.

1.3.15.3 PIPE SIZING CRITERIA

(a) All piping required for HVAC systems shall be sized based on the criteria listed in the following subparagraph.

(b) Water losses, pressure loss, etc., for sizing piping shall be based on "Cameron Hydraulic Data": With $C = 100$ for open (cooling tower) systems and $C = 150$ for closed systems. For closed systems, the maximum friction loss shall be 1200 mm (4 ft) of water per 30 m (100 ft) of pipe with maximum velocity of 1.2 m/s (4 fps) for systems in occupied areas, and up to 2.4 m/s (8 fps) for mains and large branches. For open systems, the maximum friction loss shall be 1200 mm (4 ft) of water per 30 m (100 ft) of pipe and a maximum velocity of 2.4 to 3.0 m/s (8 to 10 fps). The minimum pipe size shall be 20-mm (3/4-inch).

1.3.15.4 DUCT SIZING

(a) Duct systems should be designed in accordance with the general rules outlined in the latest ASHRAE Guide and Data Books, SMACNA Manuals and Design Guide Section of the Associated Air Balance Council Manual.

(b) Supply duct system, with total external static pressure 50 mm (2 inches) and larger, shall be designed for a maximum duct velocity of 12.75 m/s (2500 fpm) for duct mains and a maximum static pressure of 6.4 mm (0.25 inch) of water gage per 30 m (100 ft). Static pressure loss and regain shall be considered in calculating the duct sizes. Size supply branch ducts for a maximum duct velocity of 7.60 m/s (1500 fpm).

(c) All other duct systems such as return and exhaust, including branch ducts, shall be designed for a maximum velocity of 7.60 m/s (1500 fpm) for the duct mains and a maximum static pressure of 0.10 inch of water gage per 30 m (100 ft), with the minimum duct area of .19 sq m (48 sq in), that is, 203 mm x 152 mm (8 in x 6 in) size. See [Article 2.11](#) for exceptions.

(d) Indicate Duct Static Pressure Construction Classification according to SMACNA (1/2", 1", 2", 3" and 4") on drawings.

1.4 CONTRACT DRAWINGS

1.4.1 GENERAL

1.4.1.1 Refer to the following Design and Construction Procedures in VHA Program Guide PG-18-3:

(a) Topic 2, Drawings

(b) Topic 7, Piping, Ducts and Electrical Conduits

1.4.1.2 Refer to VA Standard Details, VA National CAD Standard Application Guide, and National CAD Standard for symbols and abbreviations, which are to be used on all drawings and submissions. To avoid confusion and dispute, nomenclature on the drawings shall correspond exactly to nomenclature in the VA Master Specifications. Sheet notes and general type notes should be listed on the right hand

side of the sheet. Lettering on drawings shall be minimum 32 mm (1/8 inch) high.

1.4.2 SPECIFIC REQUIREMENTS

The contract drawings shall include those listed below. For uniformity, drawings shall be arranged in the order listed.

- (a) General Notes, Abbreviations and Symbols.
- (b) VA Standard Equipment Schedules. Include schedules for existing air handling units, fans, pumps, etc., that will require alteration or rebalancing.
- (c) VA Standard Details and other necessary details.
- (d) Flow Diagrams for Air Supply, Return and Exhaust for each HVAC system.
- (e) Temperature Control Diagrams and Sequence of Operation for all HVAC Systems, including "Sequence of Operation" written on the drawings alongside the control diagrams.
- (f) Flow and Control Diagrams for Chilled Water and Hot Water Systems. Flow diagrams shall show entire system on a single drawing. See [Article 2.12.13](#) for Documentation Requirements.
- (g) Flow and Control Diagrams for Refrigeration Systems.
- (h) Flow and Control Diagrams for Steam and Condensate Piping Systems.
- (i) Riser Diagrams for chilled water, hot water, drain, steam and condensate and supply air, return air and exhaust air systems where applicable. Required flow diagrams may eliminate the need for riser diagrams.
- (j) Demolition of existing HVAC work, if applicable. Minor demolition may be shown on new construction drawings. Extensive demolition requires drawings for demolition only.
- (k) Floor Plans 1:100 (1/8" = 1'-0") for Equipment, Piping and Ductwork.
- (l) Floor Plans and Sections 1:50 (1/4" = 1'-0") for Mechanical Rooms.
- (m) Floor Plans 1:50 (1/4" = 1'-0") for Mechanical Chases at each floor showing ducts, dampers, piping and plumbing.
- (n) Sections shall be shown, as required, to clarify installation, especially thru areas of possible conflict. Show all the equipment including plumbing and electrical.
- (o) Room numbers and names shall be shown on HVAC plans at every review stage including schematic submissions. Where there is insufficient room on HVAC floor plans to show room names, room numbers only may be shown on the floor plan with the room numbers and names tabulated on the drawing.

1.4.3 EQUIPMENT SCHEDULES

1.4.3.1 Equipment schedules shall be listed in the following order, vertically, from left to right, to facilitate checking and future reference. Trade names or manufacturers model numbers shall not be shown.

- (a) Air Conditioning Design Data (Outdoor and Indoor Design Conditions for the various occupancies)
- (b) Air Flow Control Valves
- (c) Air Flow Measuring Devices
- (d) Air Handling Equipment
- (e) Air Separators
- (f) Chillers, Condensing Units, Air Cooled Condensers
- (g) Heat Exchangers
- (h) Cooling Towers
- (i) Engineering Control Center
- (j) Expansion Tanks
- (k) Fans
- (l) Fan-coil Units, Air Terminal Units (Boxes)
- (m) Filters for closed loop Water Systems (chilled water and hot water)
- (n) Finned Tube Radiation
- (o) Heat Recovery Equipment
- (p) Humidifiers
- (q) Pre-filters and after-filters (may be combined with pre-filters)
- (r) Preheat Coils, Cooling Coils, Reheat Coils
- (s) Pressure Reducing Valves, Safety Valves
- (t) Pumps
- (u) Radiant Panels
- (v) Room By Room Air Balance
- (w) Sound Attenuators

(x) Supply, Return and Exhaust Air Diffusers and Registers

(y) Unit Heaters

(z) Vibration Isolators

(aa) Water Flow Measuring Devices

(bb) Other Schedules As Required

1.4.3.2 Equipment performance and capacity data shall correspond to that shown in the calculations, not a particular manufacturer's catalog data, but the data shall be in the range of available manufactured products.

1.4.3.3 Heat exchangers, coils, pumps and chillers in glycol-water system shall be identified on the equipment schedule showing the percent glycol by volume of the circulating fluid for equipment de-rating purposes.

1.4.4 PIPING DRAWINGS

(a) Avoid piping routing through rooms containing electrical or communication equipment.

(b) Branch piping serving each floor shall have shut-off valves at mains to isolate branch.

(c) Show sections or profiles of underground piping to show elevation with respect to grade, roads and possible conflicting utilities, including provision for draining and venting.

(d) The quantity of rock excavation for HVAC work shall be shown on the "MH" drawings.

(e) All HVAC piping 150 mm (6 inch) diameter and larger shall be shown in double line on all drawings.

1.4.5 DUCTWORK DRAWINGS

1.4.5.1 All ductwork, without any exceptions, shall be shown in double line. The minimum duct size shall be 200 mm x 150 mm (8 inch x 6 inch).

1.4.5.2 Complete flow diagrams of the supply return and exhaust air systems shall be shown on the drawings. Flow diagrams shall show the Cu M/Min (CFM) required in all mains and major branches (such as zone/floor) and the size of each main and major branch. Flow diagrams shall show and identify all air handling units, fans, and other major components in the air system. These diagrams are to facilitate checking and air balancing.

1.4.5.3 Manual air volume balancing devices shall be provided in supply return and exhaust mains, branch mains and terminal branches. Ceiling access panels are to be installed, where required, for access to balancing devices. Location of balancing devices shall be shown on the contract drawings.

1.4.5.4 Dampers in room diffusers and registers shall be used only for minor balancing requiring a maximum pressure drop of approximately 25 Pa (0.10 inch of water gage). Registers and/or diffusers shall not be located on main ducts or main branches. They shall be located on individual branch ducts with opposed blade balancing dampers in the branch to reduce room noise transmission.

1.4.5.5 Air quantities on plans shall be "rounded off" to the nearest increment of 0.30 Cu M/Min (10 CFM).

1.4.5.6 Smoke detectors for air conditioning systems are specified in the Electrical Specifications, but the locations at air handling units shall be shown on the "H" drawing control diagrams and floor plans. Coordinate diffuser location and blow direction with space detector locations shown on the Electrical Drawings to avoid false smoke alarms caused by air discharge.

1.4.5.7 Provide fire dampers and smoke dampers in accordance with [Article 2.13](#) "Smoke and Fire Protection". Provide a schedule for smoke dampers showing sizes, pressure drops, and compliance with the maximum velocity limit. Show duct transitions on drawings.

1.5 HVAC CALCULATIONS, ANALYSES AND REVIEW SUBMITTALS

1.5.1 CALCULATIONS

1.5.1.1 Calculations shall include room by room heat gain and loss; room by room air balance showing supply, return, exhaust, transfer, and make-up air quantities; equipment capacities; economic analysis; and sound and vibration analysis. Calculations and analysis should be identified, arranged and summarized in proper format. They shall be indexed in a bound folder with each air handling unit as a zone and separate chapters for cooling loads, heating loads, exhaust systems, pumping/piping calculations, fan selections, etc.

1.5.1.2 Heat transfer coefficients, solar radiation, psychrometrics, duct and pipe sizing, etc., and calculations and analysis shall be in accordance with the ASHRAE Handbooks and VA Design Criteria.

1.5.1.3 Fan and pump motor horsepower, reheat, and duct heat gains shall be included in cooling load calculations.

1.5.1.4 In addition to internal loads for people and lights include heat gain from equipment, such as sterilizers, X-ray, washers, burners, ovens, refrigerators and dietetic.

1.5.1.5 The use of computer programs and calculations is acceptable and desirable. Calculations should, however, be keyed to appropriate room, zone, and unit numbers for each identification.

1.5.2 ECONOMIC ANALYSIS

1.5.2.1 Economic analysis concerning cost of steam generation shall be based upon fuel cost and boiler plant efficiency. Use plant efficiency of 75 percent, unless information to the contrary is available. No labor or maintenance (included in steam cost calculated by the station) should be included in the cost of additional steam generated. Analysis

should include an assessment of future availability of fuels, particularly natural gas.

1.5.2.2 Economic analysis concerning electrical energy cost should be calculated on a monthly basis in accordance with the utility companies rate schedule and bill monthly on a kW demand charge plus step rates for kW-hr consumption. The present station kW demand and kW-hr consumption shall be the base load for electrical energy calculations. Analysis shall include the rate schedules and calculations showing application of the schedule.

1.5.3 REVIEW SUBMITTALS

In addition to calculations and drawings, the design submission shall include copies of the equipment selection engineering data (handwritten worksheets) by unit number, including the following:

1.5.3.1 Air handling unit capacity and sketch of component arrangement with physical dimensions for louvers, dampers, access provisions, filters, coils, fans, vibration isolators, etc.

1.5.3.2 Required performance (Pressures, flow rate, horsepower, motor size, etc.) for all air handling units, fans and pumps for intended modes of operation. Include fan and pump performance curves.

1.5.3.3 Coil selections for preheat, heating, cooling and energy reclaim

1.5.3.4 Heat recovery equipment

1.5.3.5 Refrigeration equipment loading, performance and selection

1.5.3.6 Cooling tower performance, winterization (heaters) and noise analysis

1.5.3.7 Sound attenuation for fans, ductwork and terminals

1.5.3.8 Steam PRVs, by-pass and safety valves

1.5.3.9 Typical catalog cuts of major equipment

1.6 HVAC CALCULATIONS FOR HIGHER ELEVATIONS

1.6.1 GENERAL

For sites with elevations below 1,000 feet, the effect of the change in air density is minor and, therefore, need not be considered while calculating the HVAC design quantities. The standard air density is 1.20 Kg/Cu M (0.075 Lb./Cu Ft), at sea level, when the atmospheric pressure is 763 mm (29.92 inches) of mercury and the ambient temperature is 21 degrees C (70 degrees F).

1.6.2 AIR DENSITY RATIO

For elevations higher than 1,000 feet, the density of air is less. Air Density Ratio (ADR) should be used while converting any engineering entity from a standard value to the actual value.

$$\text{ADR} = \frac{\text{Air density at higher elevation}}{0.075 \text{ standard density}}$$

Table 1-7 Air Density Correction Factors

Elevation (Feet)	ADR
2000	0.944
4000	0.890
6000	0.838

1.6.3 DENSITY CORRECTIONS

The density corrections to various parameters is applied as follows:

(a) CFM_1 = Standard CFM at 0.075 density

$$CFM_2 = \text{Actual CFM at Elevation} = \frac{CFM_1}{ADR}$$

(b) Coil Face Area = $\frac{CFM_2}{\text{Face Velocity}}$

(c) Air Friction Thru Equipment = $\frac{\text{Catalog Air Friction } CFM_1}{ADR}$

(d) Air Friction Thru Ductwork = $\frac{\text{Air Friction at } CFM_1}{ADR}$

(e) Fan Total Static Pressure = SP₂ for Equipment + SP₂ Ductwork + System Effect; System Effect is defined as losses due to fan inlet and outlet conditions and obstructions due to bearings, supports, etc.

(f) Fan RPM at actual conditions is to be obtained at SP₂ and CFM₂ on the fan curve.

(g) Actual BHP absorbed is at CFM₂ and SP₂.

(h) The air density ratio and elevation should be noted on the equipment schedule together with actual CFM, SP, RPM, and BHP.

1.7 EQUIPMENT LOCATION AND INSTALLATION

1.7.1 GENERAL

Equipment shall be located to be accessible for installation, operation and repair. Mechanical spaces shall be of suitable size to permit inspection and access for maintenance, and to provide space for future equipment when required. The effect that equipment noise or vibration might have on areas adjacent to, above, and below equipment shall be considered. Location of equipment remote from sound sensitive areas should be emphasized. Design shall comply with specified room sound ratings.

1.7.2 HVAC EQUIPMENT

Air handling units and similar equipment shall be housed in a mechanical equipment room or in a mechanical penthouse building. Penthouse type of fully weatherized roof top units constructed in standard sections of modules would be acceptable in lieu of the mechanical equipment rooms or mechanical penthouses. These units shall

provide excess sections for walk through servicing, maintenance, and shall ensure that the piping connections and electrical conduits are fully enclosed within the units. The designer shall ensure close coordination with the architecture and structural disciplines for aesthetics, operating weight, shaft locations, etc., while selecting the roof top units.

1.7.3 COORDINATION

Coordinate and make provisions for all necessary stairs, cat walks, platforms, steps over roof mounted piping and ducts, etc., that will be required for access, operation and maintenance. Access to roofs by portable ladder is not acceptable.

1.7.4 COOLING TOWERS

Select and locate cooling towers to avoid problems with aesthetics, noise, vibrations, air recirculation or drift. Include a noise analysis of the proposed cooling tower relative to adjacent occupancies and consider alternative cooling tower selections, if necessary, to meet noise level of 60 dB(A) at 15 m (50 feet) which may be lowered for critical locations. Consider provisions for security and maintenance lights and receptacles. Provide a permanent service platform and ladders for access to cooling tower basin access doors.

1.7.5 AIR COMPRESSORS

Large control air compressors can be a source of objectionable noise and vibration. They should be mounted on vibration isolators and should be located to avoid noise problems in occupied areas, including shops and the engineering control center. Compressors may require an enclosure or acoustical treatment.

1.7.6 SCREENS AND FILTERS FOR AIR

At medical centers where cottonwood trees, or similar types, are likely to interfere with operation of air intakes for air handling units, cooling towers, or air cooled condensers, provide easily cleanable screens or roughing filters at the air inlets.

1.8 LOCATIONS OF OUTSIDE AIR INTAKES AND EXHAUST AIR OUTLETS

1.8.1 GENERAL

Outside air intake and exhaust air outlets shall be located to avoid health hazards, nuisance odors and reduction in capacity of air conditioning equipment and corrosion of equipment caused by re-entry of exhaust air from laboratories, transportation systems, cooling towers and air cooled condensers, etc.

1.8.2 MINIMUM REQUIREMENTS

1.8.2.1 The bottom of all outdoor intakes shall be located as high as practical but not less than three feet above ground level or, if installed through the roof, one meter (three feet) above the roof level.

1.8.2.2 Operating Room system air intakes shall be at least 9 m (30 ft) above the ground.

1.8.2.3 Laboratory and Research exhaust shall be terminated at the highest point of the building (NFPA 99, 5-3.3.4).

1.8.2.4 Outside air intake shall not be near hot exhaust discharging horizontally or deflected down, nor be near plumbing vents, animal room exhausts, generator exhausts, loading docks, automobile entrances, driveways, passenger drop-offs, cooling towers, incinerator and boiler stacks.

1.8.2.5 Louvers shall be designed for a maximum velocity of 3.8 m/s (750 fpm) through the free area of 35 percent. Drainable louvers may be designed for a maximum velocity of 5.0 m/s (1000 fpm) and 45 percent free area.

1.8.3 SPECIAL REQUIREMENTS

Separating air intakes and exhaust air outlets by 10 m (30 ft) as recommended by codes is a minimum requirement under ideal conditions. Other factors such as wind direction, wind velocity, stack effect, system sizes, and height of building must be evaluated and location of intakes and outlets shall be adjusted as required. Refer to Chapter "Air Flow Around Buildings" of ASHRAE Fundamentals Handbook for analyzing these factors.

1.8.4 TYPE OF LOUVERS

1.8.4.1 The type of louvers depends upon the application and should be coordinated with architectural drawings and specifications. The desired performance characteristics for each type of louver should be listed in Section 10200, LOUVERS AND WALL VENTS.

1.8.4.2 Flat blade (non-drainable) louvers are recommended for most applications.

1.8.4.3 Drainable louvers should be considered for applications where available area is restrictive. Example: Emergency Generators. Drainable louvers are also recommended for situations where the air handling unit pre-filters are in close proximity of the outside air intake.

1.8.4.4 The use of the drainable louvers is discouraged for areas where dirt and debris may clog drain gutters.

1.9 ENERGY CONSERVATION

1.9.1 GENERAL

The HVAC systems design shall be designed to conform to the mandatory energy conservation guidelines outlined in Article 1, [Paragraph 1.1.7](#).

1.9.2 BUILDING THERMAL ENVELOPE

1.9.2.1 NEW CONSTRUCTION: The building thermal envelope for the new VA health care facilities shall be energy efficient to minimize the heat gain and loss due to conduction and solar radiation. The building envelope shall minimize the air leakage to and from the occupied spaces and shall also ensure condensation control.

(a) Recommended "U" Values: The following represents the recommended "U" values of walls, roof and glass, and the Shading Coefficients (SCs) of glass for new construction. These values should be used to meet the overall U_o factor, for the building gross wall area, defined under the next paragraph.

Table 1-8 Recommended Building Thermal Envelope For New Construction

Degree-Days	Wall "U"	Glass "U"/SC	Roof "U"	Floor "U"
3000 & Below	0.27 (0.13)	1.50 (0.75)/0.40	0.10 (0.05)	0.24 (0.12)
3001 to 5000	0.20 (0.10)	0.80 (0.40)/0.50	0.10 (0.05)	0.20 (0.10)
5001 & Above	0.14 (0.07)	0.70 (0.35)/0.33	0.06 (0.03)	0.16 (0.08)

(b) Notes:

(1) The degree-days are based on the heating season when outdoor temperatures are below 48 degrees C (65 degrees F), in accordance with ASHRAE Handbooks-Fundamentals and Systems.

(2) The SCs of the glass windows are based on the intrinsic property of the glass material only, that is, without any assistance from the external shading devices, such as, venetians blinds and/or curtains.

(3) Insulating glass with lower "U" value might be necessary to prevent condensation while maintaining the required 30 percent Relative Humidity (RH) in perimeter spaces with -4 degrees C (25 degrees F) outdoor design temperature and below.

(4) The "U" values are expressed as W/Hr/Sq M/ degrees C (BTUH/Hr/ Sq Ft/degrees F).

(5) The "U" values are for floors of heated spaces over unheated areas, such as sub-basements (pipe basements), garages, crawl spaces, etc. The requirements of insulation for the slabs-on-grade for the heated spaces are shown under perimeter insulation.

(c) Table below lists Overall "Uo" Factors and Degree Days:

Table 1-9 Recommended Overall "Uo" Factors for New Construction

Degree-Days	Uo (Overall)
3000 & Below	0.73(0.36)
3001 to 5000	0.63(0.31)
5001 & above	0.57 (0.28)
$U_o = \frac{U_w \times A_w + U_g \times A_g + U_d \times A_d}{A_o}$	
Uo = Overall Transmission Factor	
Ao = Overall Gross Wall Area	
Uw = Wall "U" factor	
Aw = Wall Area	
Ug = Glass "U" Factor	
Ag = Glass Area	
Ud = Door "U" Factor	
Ad = Door Area	

Table 1-10 Recommended Perimeter Insulation

Degree-Days	Insulation Thickness
3000 & Below	25 mm (1 inch)
3001 & Above	50 mm (2 inch)
The insulation shall have "R" value (same units "U") of 5.0	

1.9.2.2 Existing Construction: The designer shall examine the existing building envelope and recommend the ways and means to improve its thermal efficiency. It is recognized that retrofitting the existing walls with new insulation is expensive; however, it should be evaluated if economically and technically feasible. The existing single pane windows shall, however, be replaced by insulating double pane windows ("U" Factor 0.5 & Shading Coefficient 0.5) as a part of the major renovation effort involving heating, mechanical cooling, and winter humidification.

1.9.3 DESIGN FEATURES

In addition to energy studies and decisions made in conjunction with economic analysis, the following features shall be incorporated without the need for a life cycle cost analysis.

1.9.3.1 Air conditioning systems shall be designed to operate below 8.6 degrees C (48 degrees F) outdoor temperature without refrigeration, unless such refrigeration is used effectively as a heat pump with overall energy savings.

1.9.3.2 Heat Recovery Devices: For all locations where the outdoor winter design temperatures are below -1 degrees C (30 degrees F) and the winter degree days are in excess of 3000, heat recovery devices, comprising of either air to air plate heat exchangers or glycol run around loop heat recovery coils, shall be installed in all 100 percent outdoor air systems with capacities in excess of 85 Cu M/Min (3000 CFM). The exhaust air systems, from which the heat is to be extracted, shall also have capacity in excess of 85 Cu M/Min (3000 CFM) per exhaust fan, and shall be of continuously operating type. Controls for heat recovery system shall be designed to avoid defeating any "free cooling" (economizer cycle) operation. Controls shall also be designed to avoid overheating the outdoor air during mild or warm weather and prevent icing of the exhaust air coil below 0 Degrees C (32 Degrees F) ambient air temperatures. Do not provide heat recovery systems in the following special exhausts:

- (a) All Fume Hood Exhaust
- (b) Kitchen Exhaust (Range Hood and Wet Exhaust)
- (c) Autopsy Exhaust
- (d) Isolation Room Exhaust
- (e) Wet Exhaust From Cage and Cart Washers
- (f) ETO - Ethylene Oxide Sterilizers Exhaust

1.9.3.3 Except in spaces where constant air change rate and/or critical pressure differential relationship are essential, variable air volume

terminal units with or without reheat coils shall be used when all air systems are selected. See VAV Systems [Article 2.4](#) for specific design considerations.

1.9.3.4 Perimeter heating: See [Paragraph 2.7.2](#).

1.9.3.5 Energy Efficient Motors: Refer to the VA Standard Detail 15000-50 for application and schedule.

1.9.4 THERMAL STORAGE AND MAJOR CONSERVATION SYSTEMS

The evaluation of a thermal storage (Example, Ice Storage) or any major energy conservation project shall be based on the following considerations:

1.9.4.1 The system shall be a non-proprietary, proven technology, which can be supplied by at least two, preferably more, manufacturers.

1.9.4.2 The A/E shall have prior satisfactory design, construction, and operational experience of the similar projects.

1.10 DESIGN FOR EXISTING BUILDINGS

1.10.1 GENERAL

1.10.1.1 The designer is responsible for surveying the existing buildings to determine if adequate space is available for ducts and equipment. He must not rely upon the station furnished as built drawings alone. Early in the design stage, arrangements must be made with the Station Engineering Officer for access above ceilings to determine field conditions and to locate existing HVAC including steam lines and other services. Consider that most corridor ceiling spaces are loaded with equipment to remain and may create installation problems for new equipment. Provide sections to resolve conflicts. Required demolition of existing HVAC work must be shown on the drawings. Location of new equipment and services must be coordinated with all involved parties. Phasing of the construction work must be coordinated with operation of the facility and VA staff and be provided for in the design.

1.10.1.2 In existing buildings, the floor-to-floor heights are generally less than 3.6 m (12 feet). In addition, the building structure elements also occupy substantial spaces between the underside of the slab and the suspended ceilings. The installation of an all air system is therefore very difficult, if not impossible. During the schematic stage, the A/E shall make a detailed evaluation of the available space and determine whether the installation of an all air system is feasible. If all air systems are not feasible, the need to perform a life cycle cost analysis shall be reviewed with the VA Reviewer.

1.10.1.3 If the VA medical center wishes to retain the existing HVAC equipment, considered obsolete as a result of modification, this should be noted on the demolition drawings; otherwise, the contractor in accordance with the General Conditions of the contract will dispose it off.

1.10.1.4 Investigate the conditions of the existing steam supply and condensate return piping and provide recommendations.

1.10.2 EXISTING SURGERY UNIT

When air conditioning buildings, the existing surgery air-handling unit, ducts, and refrigeration unit shall be replaced or upgraded, as required, to meet current VA HVAC Criteria. See [Article 3.21](#) for Surgery Suites Systems.

1.10.3 HVAC SYSTEM UPGRADE

Unless directed, or approved otherwise by VA, the existing steam radiators or convectors heating systems shall be dismantled and hydronic hot water heating system shall be provided when air conditioning systems with mechanical cooling are added to an existing building.

1.10.3.1 If the existing radiators or convectors are to remain in place, the scope of work, at a minimum, shall include installation of new modulating control valves in the steam supply lines and installation of new float and thermostatic steam traps in the steam condensate return lines. In addition to that, the room temperature control sequence shall be arranged in such a manner that a single room thermostat shall control cooling and heating, in sequence, to avoid any possibility of mechanical cooling and steam heating to be in operation together. The installation of the new steam control valves and new steam traps involve considerable expense for retrofitting and existing steam terminal heating devices. This expense should be carefully weighed before deciding against hydronic hot water heating systems.

1.10.3.2 If the existing steam heating systems are equipped with any zone control arrangement, the same should be disconnected in place so that the zone controls do not create any operating conflict with the room temperature controls proposed above.

1.10.3.3 When air conditioning an existing hospital that has porches at the end of wings, size piping, ducts and equipment for future enclosure and air conditioning of the porches.

1.11 CERTIFICATION OF BUILDING ENERGY PERFORMANCE

LOCATION:

PROJECT TITLE:

PROJECT NO:

PROJECT MANAGER:

I certify that the energy performance of the above project fully satisfies the energy efficient requirements of DOE regulations, 10 CFR Part 435, "Energy Conservation Voluntary Performance Standards for Commercial and Multi-Family High Rise Residential Buildings; Mandatory for New Federal Buildings, Interim Rule" with the exception of special requirements listed in the VA HVAC Design Manual for Hospital Projects dated -----.

NAME & TITLE

Name Address of Architect-Engineer Firm:

Title/Position:

Professional Registration No.:

State Where Registered (use seal):

Blank Sheet Left intentionally

CHAPTER 2: HVAC SYSTEMS AND EQUIPMENT

- 2.1 HVAC SYSTEM SELECTION REQUIREMENT
 - 2.1.1 GENERAL
 - 2.1.2 EXISTING BUILDINGS
- 2.2 SPECIAL REQUIREMENTS FOR ALL AIR SYSTEMS
 - 2.2.1 VARIABLE AIR VOLUME (VAV) SYSTEMS
 - 2.2.2 INTERIOR ROOMS
 - 2.2.3 TERMINAL REHEAT SYSTEM
 - 2.2.4 DUAL DUCT SYSTEM
 - 2.2.5 RETURN AIR FANS
 - 2.2.6 SYSTEM ZONING REQUIREMENTS
 - 2.2.7 AIR CIRCULATION CONTROL
 - 2.2.8 CORRIDORS, TOILETS AND JANITOR CLOSETS (HACs)
 - 2.2.9 FUNCTIONAL NEEDS OF SPACES
 - 2.2.10 DEDICATED AIR HANDLING UNITS EXCEPTIONS/MODIFICATIONS TO DEDICATED AIR HANDLING UNITS
- 2.3 HVAC EQUIPMENT REQUIREMENTS
 - 2.3.1 AIR HANDLING UNITS
 - 2.3.2 FILTERS
 - 2.3.3 CENTRAL HUMIDIFIERS
 - 2.3.4 DUCT LINING AND SOUND ATTENUATORS
 - 2.3.5 HVAC DRAINS
- 2.4 VARIABLE AIR VOLUME (VAV) SYSTEMS
 - 2.4.1 GENERAL
 - 2.4.2 SPECIAL CONSIDERATIONS
- 2.5 ROOM FAN-COIL UNITS
 - 2.5.1 GENERAL
 - 2.5.2 EXCEPTION
 - 2.5.3 INSTALLATION RESTRICTION
 - 2.5.4 INTERIOR ROOMS
- 2.6 RADIANT CEILING PANEL SYSTEM
 - 2.6.1 GENERAL
 - 2.6.2 CEILING PANELS
 - 2.6.3 SPECIAL DESIGN CONSIDERATIONS
 - 2.6.4 TYPICAL DESIGN PARAMETERS (PATIENT BEDROOMS)
- 2.7 HEATING SYSTEMS
 - 2.7.1 GENERAL
 - 2.7.2 PERIMETER HEATING
 - 2.7.3 DELETION OF PERIMETER HEATING
 - 2.7.4 HYDRONIC HEATING
 - 2.7.5 STEAM HEATING
 - 2.7.6 ELECTRIC HEATING
 - 2.7.7 GAS HEATING
- 2.8 ETHYLENE GLYCOL-WATER SYSTEM
 - 2.8.1 GENERAL
 - 2.8.2 HEAT TRANSFER
 - 2.8.3 FLOW-HEAD-HORSEPOWER
- 2.9 STEAM DISTRIBUTION
 - 2.9.1 STEAM GENERATION
 - 2.9.2 OUTDOOR STEAM DISTRIBUTION
 - 2.9.3 INSIDE STEAM DISTRIBUTION
 - 2.9.4 PRESSURE REDUCING VALVES (PRV) AND STATIONS
 - 2.9.5 STEAM PIPING
 - 2.9.6 STEAM GUN SET
 - 2.9.7 STEAM TRAPS
 - 2.9.8 STEAM CONDENSATE PIPING
 - 2.9.9 VENT LINES
- 2.10 VENTILATING SYSTEMS
 - 2.10.1 GENERAL
 - 2.10.2 OCCUPIED AREAS
 - 2.10.3 UNOCCUPIED AREAS
 - 2.10.4 TRASH COLLECTION AREAS
 - 2.10.5 ELEVATOR MACHINE ROOMS
 - 2.10.6 EMERGENCY GENERATOR ROOM
 - 2.10.7 TRANSFORMER ROOMS (VAULTS) AND ELECTRIC CLOSETS
- 2.11 EXHAUST SYSTEMS
 - 2.11.1 GENERAL EXHAUST SYSTEMS
 - 2.11.2 SPECIAL EXHAUST SYSTEMS
 - 2.11.3 LABORATORY HOOD EXHAUST SYSTEMS
 - 2.11.4 AUTOPSY AND MORGUE EXHAUST SYSTEMS
 - 2.11.5 ETHYLENE OXIDE (ETO) STERILIZER EXHAUST SYSTEMS
 - 2.11.6 ISOLATION SUITE EXHAUST SYSTEMS
 - 2.11.7 KITCHEN EXHAUST SYSTEMS
 - 2.11.8 NURSE SERVER CABINET EXHAUST
 - 2.11.9 ORTHOTIC/PROSTHETIC LABORATORY EXHAUST
 - 2.11.10 BATTERY CHARGING ROOM EXHAUST
 - 2.11.11 ANIMAL RESEARCH AREA
 - 2.11.12 MAINTENANCE GARAGES
- 2.12 REFRIGERATION SYSTEMS FOR AIR CONDITIONING
 - 2.12.1 GENERAL
 - 2.12.2 CENTRAL CHILLED WATER PLANT
 - 2.12.3 CENTRAL CHILLED WATER PLANT FLOW DIAGRAM
 - 2.12.4 SECONDARY DISTRIBUTION INTERFACE FLOW DIAGRAM
 - 2.12.5 SECONDARY/TERTIARY DISTRIBUTION INTERFACE FLOW DIAGRAM
 - 2.12.6 DX REFRIGERATION SYSTEMS
 - 2.12.7 REFRIGERATION SYSTEMS FOR SURGERY SUITES
 - 2.12.8 REFRIGERATION SYSTEMS FOR ANIMAL RESEARCH AREAS
 - 2.12.9 REFRIGERATION SYSTEMS FOR SPECIALTY AREAS (LINEAR ACCELERATORS, MRI, TELEPHONE EQUIPMENT ROOMS AND ELEVATOR MACHINE ROOMS)
 - 2.12.10 FREEZE PROTECTION
 - 2.12.11 COOLING TOWERS
 - 2.12.12 PRE-INSULATED CHILLED WATER PIPING
 - 2.12.13 DOCUMENTATION REQUIREMENTS
- 2.13 SMOKE AND FIRE PROTECTION
 - 2.13.1 GENERAL
 - 2.13.2 SMOKE CONTROL
 - 2.13.3 PENETRATIONS OF FIRE AND SMOKE BARRIERS

- 2.13.4 SMOKE AND FIRE PROTECTION CONTROL
DIAGRAM

- 2.14 AUTOMATIC TEMPERATURE CONTROL
SYSTEMS
 - 2.14.1 GENERAL
 - 2.14.2 ENGINEERING CONTROL CENTER (ECC)
 - 2.14.3 STEAM RECORDING FLOW METERS
 - 2.14.4 CONTROL ROOM

- 2.15 SEISMIC REQUIREMENTS (HVAC)
 - 2.15.1 GENERAL
 - 2.15.2 CONFORMANCE WITH SMACNA
 - 2.15.3 CONFORMANCE WITH NUSIG
 - 2.15.4 CALCULATIONS
 - 2.15.5 DRAWINGS

- 2.16 EMERGENCY POWER FOR HVAC
 - 2.16.1 GENERAL
 - 2.16.2 LIST OF HVAC EQUIPMENT ON
EMERGENCY POWER

2 HVAC SYSTEMS AND EQUIPMENT

2.1 HVAC SYSTEMS SELECTION REQUIREMENTS

2.1.1 GENERAL

The HVAC System for a specific project shall be selected through an engineering economic analysis to ensure that the system is cost effective. See [Paragraph 1.1.6](#) for this requirement.

2.1.2 EXISTING BUILDINGS

Where an all-air system cannot be used due to physical limitations, VA may waive the requirement for a life cycle cost analysis. See [Article 1.10](#) for the waiver of this requirement.

2.2 SPECIAL REQUIREMENTS FOR ALL AIR SYSTEMS

2.2.1 VARIABLE AIR VOLUME (VAV) SYSTEMS

As far as possible, VAV systems shall be used with all air systems, except for spaces requiring constant air changes/hours, and/or critical pressure differentials with respect to the adjoining spaces. See [paragraph 2.4](#) for specific design considerations

2.2.2 INTERIOR ROOMS

Only all-air systems shall be used for interior space to take advantage of free cooling by an economizer cycle. When the existing exterior rooms become interior rooms because of new construction or modifications, the HVAC system for these rooms must be checked and modified to all air systems provided these rooms are not already served by all air systems. This is required even though these rooms may not be a part of the new or modification project.

2.2.3 TERMINAL REHEAT SYSTEM

Use of constant volume with terminal reheat systems shall be confined to areas such as operating rooms, SPD, laboratories, recovery, intensive care, animal research, autopsy, and BMT patient rooms, recovery rooms, donor rooms, medical preparation rooms and Spinal Cord Injury.

2.2.4 DUAL DUCT SYSTEM

For dual-duct systems utilizing 100 percent outdoor air, analyze the need for pre-cooling coils to control humidity during low load conditions.

2.2.5 RETURN AIR FANS

All air-handling units using return air shall be furnished with return air fans for economizer cycle capability, pressure relationship, and to facilitate positive control of air balance.

2.2.6 SYSTEM ZONING REQUIREMENTS

2.2.6.1 GENERAL GUIDELINES

The VA criteria for zoning HVAC systems and the selection of the type of air handling units (AHUs) is based on the specific HVAC requirements of the medical departments, life cycle cost analysis, and energy conservation. For existing facilities, considerations listed below could also influence the selection of HVAC systems.

(a) Space availability for equipment, piping, and ductwork

(b) Phasing requirements

(c) Capacities and conditions of the existing HVAC systems, if any, serving the areas to be renovated

(d) Impact of the renovation activities on the adjoining areas not included in the project

2.2.6.2 While it is desirable to follow the structural and architectural symmetry of the building by providing a dedicated AHU to service a specific module/quadrant. This approach should not compromise the functional integrity of the spaces. Generally, different medical departments are to be provided with dedicated AHUs to meet their HVAC requirements. Deviations from providing dedicated AHUs should be referred to the VA with specific information as to the extent and impact of any violations.

2.2.7 DUCTED RETURN/EXHAUST REQUIREMENTS

Return and exhaust air shall be ducted for all spaces, i.e., air shall not be taken through ceiling plenums, mechanical equipment rooms, corridors or furred spaces. Circulation of air directly between functional areas is not permitted, except for toilet rooms and janitor closets. The exhaust air to the toilet should be transferred via door undercuts or louvers. Transfer grilles are not permitted between corridor and occupied spaces.

2.2.8 CORRIDORS, TOILETS AND JANITOR CLOSETS (HACS)

Conditioned air shall be supplied to corridors, toilets, janitor closets (HACs), and bathrooms, etc., which open directly to the corridor to maintain design temperature and to provide make-up air for the exhaust air requirements.

2.2.9 FUNCTIONAL NEEDS OF SPACES

(a) Ventilation Air:

(1) 100 percent outdoor air, or

(2) Minimum outdoor air, as stipulated in [Article 1.3](#).

(b) Hours of Operation:

(1) 24 hours a day throughout the year, or

(2) 10 to 12 hours with weekend/holidays shutoff.

(c) Interior design conditions:

(1) Room temperature and humidity, or

(2) Summer and winter set points

(d) Supply air volume:

(1) Constant air volume with minimum fixed air changes per hour; or

(2) Variable air volume with flexibility to vary the supply air volume according to the fluctuations in the cooling load.

(e) Special Exhaust Air Systems: The following and other special exhaust systems outlined in [Article 2.11](#) will influence the choice of air handling systems because an operating interlock between the supply and exhaust air systems is essential to ensure the following:

- (1) Laboratory fume hood systems
- (2) Animal research exhaust
- (3) Autopsy exhaust
- (4) Kitchen range hood exhaust
- (5) Isolation room exhausts
- (6) Ethylene oxide sterilizer (ETO) exhausts
- (f) Air Pressurization

(1) Positive air pressure or negative air pressure of certain medical departments in relation to adjoining areas

2.2.10 DEDICATED AIR HANDLING UNITS

The following areas shall have dedicated air handling units complete with return and/or exhaust air fans. See [Chapter 3](#) for further details.

- (a) Animal Holding Areas
- (b) Animal Research Areas
- (c) Auditoriums, Chapels, and Theaters
- (d) Autopsy Suites
- (e) BMT (Bone Marrow Transplant) Suites
- (f) Computer Room A/C Units (for equipment cooling only)
- (g) Dental Clinics
- (h) Dietetics (Kitchen & Dining & Cafeteria)
- (i) Emergency Care Units (Part of Ambulatory Care Unit)
- (j) Intensive Care Units (ICUs)
- (k) Laboratories
- (l) Laundries
- (m) Medical Media
- (n) Magnetic Resonance Imaging (MRIs) or CT Scanner Units
- (o) Nuclear Medicine

(p) Nursing Wings (Patient Bedrooms): The following areas, generally associated with the functional needs of the nursing wing, can be served by the same air-handling unit serving the patient bedrooms.

- (1) Nurse's Station
- (2) Examination Room
- (3) Doctor's Office
- (4) Lounge
- (5) Therapy Room
- (6) Clean and Soiled Storage Rooms
- (q) Pharmacy (Inpatient)
- (r) Radiology Suites
- (s) Spinal cord Injury (SCI) units
- (t) Supply Process & Distribution (SPD) Suites
- (u) Surgical Suites
- (v) Telephone Equipment Rooms (For equipment cooling only)

2.2.11 EXCEPTIONS/MODIFICATIONS TO DEDICATED AIR HANDLING UNITS

The areas and functions listed below may (or may not) have dedicated air-handling units. Depending upon their architectural layouts and similarity of the HVAC requirements, these areas can be grouped together to be served by a common air-handling unit.

- (a) Ambulatory Care and Outpatient Examination/Treatment Rooms
- (b) Clinics and other special areas, such as:
 - (1) Audiology Suites
 - (2) Special Procedure Rooms
 - (3) ENT Clinics
 - (4) Eye Clinics
 - (5) Pharmacy (Outpatient)
 - (6) Pulmonary Areas
- (c) Medical Administration Service (MAS), Offices, and assorted areas, such as:
 - (1) Barber shops
 - (2) Chaplain

- (3) Day Treatment
- (4) Libraries
- (5) Medical Records
- (6) Nursing Administration
- (7) Recreation
- (8) Rehabilitation
- (9) Retail Stores
- (10) Security Offices
- (11) Therapy Areas
- (12) Volunteers

(d) The HVAC requirements for areas not listed above should be discussed with the VA before proceeding with the design.

2.3 HVAC EQUIPMENT REQUIREMENTS

2.3.1 AIR HANDLING UNITS

2.3.1.1 The VA preference for air-handling units is for the draw-thru type.

2.3.1.2 The blow-thru type air handling units shall generally not be used because the fully saturated air leaving the cooling coil could cause water damage to the after-filters and sound attenuators, located on the downstream side of the cooling coils. Exception: For any specific situation, if the use of the blow-thru type air-handling unit is deemed necessary, locate the after-filters on the upstream side of the supply air fans. And the duct-mounted sound attenuators shall be located as far away as possible in the supply air ducts, preferably on the downstream side of the air terminal units. A factory fabricated diffuser section shall be installed on the downstream side of the supply air fan to ensure uniform distribution of the air velocity over the face of the cooling coil. Such a deviation should, however, be reviewed with and approved by the VA before incorporating it into the design documents.

2.3.1.3 All air-handling units comprised of coils, fans, filters, etc. shall be of double wall construction. These units shall be factory-fabricated and field-assembled. The larger units could, however, be field-assembled. See VA Master Specifications Section 15763, AIR HANDLING UNITS, for further information.

Casing sections and access doors are required as per VA Standard Detail 15763-0. Show access sections and door swings on contract drawings. The air handling unit air pressure shall act to seal the access doors.

2.3.1.4 FANS: Airfoil (AF) or backward inclined blade fan wheels are preferred. However, VA does allow forward curved blade wheels with certain provisions. Refer to Fan Schedule listed in Handbook, PG-18-4, Standard Detail No. 15000-21. For variable air volume systems, with supply fan motors

5.6 kW (7.5 HP), and larger, separate variable speed motor controllers shall be used for the supply and return air fans. The variable speed motor controller may be used for smaller systems only if it is cost effective, saving 50 percent of the energy compared to the constant volume system. Evaluation of this requirement shall consider hours of operation (24 hours versus 10 hours) and part-load conditions. The variable inlet guide vanes shall not be used for fan volumetric control.

2.3.1.5 COILS

(a) Cooling coil velocity shall not exceed 2.6 m/s (500 fpm) for constant volume systems and 2.8 m/s (550 fpm) for variable air volume systems. Intermediate drain trough shall be provided for each coil bank more than one coil high. The external drain of each air handling unit coil section shall have a deep seal trap and be extended to an open sight drain.

Deep-seal traps will necessitate raising of coil section and most likely the entire unit above the floor or disposing of drainage on the floor below.

(b) Preheat coils shall generally be of glycol/water solution or steam type. If a steam preheat coil is used, the designer shall evaluate the impact of numerous parameters, such as air temperature entering the preheat coil, steam pressure, modulating or on/off steam control valve, coil length, etc. This will ensure uniform heat transfer over the coil surface and prevent stratification of air, which could result in actual freeze-up conditions or false tripping/alarms of the freezestats. Further, if a steam coil is used for 100 percent outdoor air handling units, it shall be equipped with integral face and by-pass damper and two-position steam control valve.

(c) Heating/Reheat Coils: The unit mounted heating coils shall preferably be hot water type. The face velocity of these coils shall not exceed 2.8 m/s (550 fpm).

(d) Coil Sizing: When heat recovery equipment is used, the pre-heat/heating coil and chilled water coil shall be designed to function at full load with, and without, energy recovery. All coil schedules shall show both entering air conditions.

(e) Piping: Piping to coils shall be offset and shall have shut-off valves and flanges or unions to permit removal of the coil from the side of the air handling unit.

2.3.2 AIR FILTERS

(a) General: For the critical areas, such as surgical suites, recovery rooms, and intensive care units, the after-filters shall be located on the downstream of the supply air fans. A factory fabricated diffuser section shall be installed between the fan and the filters to ensure uniform distribution of air velocity over the face of the after-filters. For others areas, pre-filters and after-filters shall be located on the upstream side of the supply air fan in the same frame.

(b) Filters Efficiencies:

(1) Efficiencies shall comply with test method specified by ASHRAE standard 52.1.

(2) Filters for room fan coil units and packaged air conditioners shall be manufacturer's standard.

(3) Filters for the central ventilation air handling units providing minimum outdoor air for fan coil systems or radiant ceiling panel systems, shall be equipped with 50 mm (2 inch) thick throw-away pre-filters of 15 percent efficiency and after filters of 60 percent efficiency. For patient care areas such as patient bedrooms, examination and treatment rooms etc., after-filters shall be 85 percent efficient.

(4) Filters for the central air handling units serving patient bedrooms, examination and treatment rooms, etc., shall be equipped with pre-filters of 30 percent efficiency and after-filters of 85 percent efficiency. For critical areas, the after-filter efficiency would be as high as 99.97 percent efficiency.

(5) Following Table 2-1 lists filters efficiency for various areas:

Table 2-1 FILTER EFFICIENCIES (PERCENT) FOR ALL AIR SYSTEMS

Area Served	Pre-filters (Efficiency)	After-filters (Efficiency)
Animal Holding Areas	30	85
Animal Operating Rooms	30	95
Administrative areas, conference rooms, and lobbies	15	60
Auditoriums, Chapels, and Theaters	15	60
Autopsy Suite exhaust	30	99.97; HEPA Filters
Autopsy Suites supply air	30	85
BMT Suites	30	99.97; HEPA Filters
Burn Unit	30	99.97; HEPA Filters
Clean supplies and processing areas	30	85
Dental Clinics	30	85
Dialysis Rooms	30	85
Dietetics (Kitchen and Dining areas)	15	60
Emergency Care Units (Ambulatory Care}	30	85
Gymnasium	15	60
Heat recovery Units (In exhaust air on upstream side of the coil)	30	-
Human Immunodeficiency Virus (HIV)	30	99.97; HEPA Filters
ICUs utilizing return air system	30	99.97; HEPA Filter
ICUs and Recovery Rooms in surgical suite	30	95
Isolation Room exhausts. For TB isolation, see Article 3.22	30	99.97; HEPA Filters
Laboratories, supply system	30	85
Laundries, soiled holding areas, and bulk storage	30	-
MRI, CT Scanners, and Linear Accelerators	30	85
Nuclear Medicine	30	85
Operating Rooms, and Trauma rooms	30	95

Area Served	Pre-filters (Efficiency)	After-filters (Efficiency)
Orthopedic Surgery	30	99.97; HEPA Filters
Medical Media	30	85
Make-up units for lab and kitchen range hood	30	-
Patient Bed Rooms	30	85
Patient care such as examination, and treatment areas.	30	85
Pharmacy	30	85
Radiation Therapy	30	85
Radiology	30	85
Special Procedure Rooms	30	85
Spinal Cord Injury Unit (SCIU)	30	85
SPD	30	85
Warehouses	30	-

(a) Notes:

(1) See [Article 2.11.3](#) for laboratory hood filtration requirements.

(2) See [Article 3.6](#) for BMT area.

(3) 50 mm (2 inch) thick-away filters with 15 percent efficiency are not rated or tested as per ASHRAE standard 52.1.

(4) See VA Master Specification Section 15885, "AIR FILTERS" for filter grades, percent, nominal efficiency and application.

(5) Design face velocity should not exceed 2.5 m/s (500 FPM) for all filters. Preferred filter dimensions are 600 mm x 600 mm (24 inch x 24 inch). See Specifications Section 15885, "AIR FILTERS" for recommended pressure drop. Return and outdoor air (mixed air) shall pass through pre-filters and after-filters.

2.3.3 CENTRAL HUMIDIFIERS

(a) Central humidifiers shall be steam manifold jacketed type with duct mounted sensor/controller and high limit control. To protect the after-filter from moisture, the humidifier shall be installed downstream of the after-filter.

(b) The A/E shall consider use of chemically untreated steam source that does not require use of facility's boiler steam, and make recommendations to VA before proceeding with design.

2.3.4 DUCT LINING AND SOUND ATTENUATORS

(a) Field applied duct lining is not permitted in the supply air ducts. Omission of duct lining usually requires sound attenuators in the ductwork to meet the specified NC criteria. Perform sound analysis to ascertain the need for sound attenuators.

(b) Air Terminal Units: Factory applied fiberglass liner, with coating to prevent erosion and no exposed edges, is permitted in air terminal units located downstream of the after-filters.

Exception: Terminal units in supply air duct for operating rooms shall be unlined.

2.3.5 HVAC DRAINS

2.3.5.1 General

(a) All condensate from air conditioning equipment and other HVAC drains, including cooling tower overflow and floor drains, shall discharge into the sanitary sewer system.

(b) Drains from air conditioning equipment shall terminate, with an air gap, above the flood level rim of plumbing fixtures, such as floor drain, floor sink, sink, or open sight drain. Direct connection to the plumbing system shall not be permitted.

(c) Open-sight drains are not permitted in concealed spaces.

2.3.5.2 Fan Coil Units, Run-around Heat Recovery Coils and Computer Room A/C Units:

(a) These units shall have condensate drain lines, even if designed for sensible cooling only.

2.3.5.3 Specific Requirements

(a) Avoid condensate drains discharging through outdoor walls, unless specifically approved by the VA.

(b) Show all condensate drain piping on drawings including the drain traps. See VA Standard Detail 15705-10.

(c) Minimum horizontal drain pipe shall be 20-mm (3/4-inch).

(d) Maximum horizontal run shall be 12 m (40 feet). Provide cleanouts in drain piping.

(e) Provide a sufficient number of unit drain risers to permit a slope in the horizontal drain lines of at least 25 mm (one inch) per 12 m (40 feet).

(f) Deep seal traps are required on air handling units. Proper installation of these traps will typically require raising the air handling unit or locating the traps below the floor level.

2.4 VARIABLE AIR VOLUME (VAV) SYSTEMS

2.4.1 GENERAL

(a) VAV systems shall be single duct with or without terminal, preferably hot water reheat coils or dual duct type.

(b) All patient bedrooms and exterior and interior patient care areas, such as treatment and examination rooms shall have reheat coils in the air terminal units.

(c) Pressure-independent terminal units with factory set, but field adjustable, maximum and minimum air volumes settings are required.

(d) See [Article 1.3](#) for ductwork.

(e) See VA Standard Detail 15000-29 for VAV terminal units sound ratings.

2.4.2 SPECIAL CONSIDERATIONS

(a) For all occupied patient spaces, exterior and interior, the minimum setting of air terminal units shall be such that the minimum ventilation needs of the occupants are met at all times. Provide reheat coils for the terminal units serving the perimeter spaces.

(b) For the interior spaces serving the patient areas, such as examination and treatment rooms etc., the air terminal units shall be equipped with reheat coils to ensure minimum ventilation at all times. For the remaining non-patient interior spaces, the air terminal units can assume fully closed position when the internal heat gain is non-existent.

(c) During winter occupied mode, when the supply air volume is expected to be less than the design summer air volume, evaluate the following parameters:

(1) Supply and return air volumes and the fan performances at part-load conditions.

(2) Winter mixed air conditions and the need for a preheat coil.

(d) The volumetric control for the supply and return air fans shall be accomplished by the airflow measuring devices and the variable frequency drives. The sequence of operation shall be such that the constant difference in air quantity shall be maintained between the supply and return airflows from full load to part load conditions.

2.5 ROOM FAN-COIL UNITS

2.5.1 GENERAL

(a) Use of fan coil units for cooling in new construction areas, as well as cooling of patient care and waiting areas in the high humidity areas of the country is not permitted. However, in existing buildings with physical limitations such as inadequate furred ceiling and shaft spaces and mechanical rooms for equipment and ductwork use of fan coil units is permitted. Areas having above mean annual dew point temperature of 40-45 degrees are considered high humidity areas.

(b) Floor mounted, vertical, four-pipe fan coil units (located under the windows) shall be used for perimeter patient rooms, offices, and other exterior spaces requiring mechanical cooling, provided the system is proved to be cost effective on the basis of a life cycle cost analysis when compared with other HVAC systems. The minimum outdoor air for this system shall be directly distributed to the spaces from central air handling unit (s) via ductwork and air outlets. The outdoor air shall either be exhausted through the patient toilets or directly from the spaces. The minimum outdoor air shall meet requirements of [Article 1.3.5](#), and meet exhaust needs and space latent load.

2.5.2 EXCEPTION

Where approved by the VA for austere projects in mild climate areas, with Winter Design Temperature 4 degree C (40 degrees F) or above, outdoor air may

be taken through the wall at each fan-coil unit provided automatic intake dampers are used.

2.5.3 INSTALLATION RESTRICTION

Ceiling mounted (above or below the suspended ceiling) fan coil units are not permitted, unless there are physical limitations in an existing building where it is not possible to install them under the windows.

2.5.4 INTERIOR ROOMS

Fan-coil units shall not be used in interior rooms where chilled water may not be available to handle the cooling load in cold weather.

2.6 RADIANT CEILING PANEL SYSTEMS

2.6.1 GENERAL

2.6.1.1 Use of radiant ceiling panels for cooling in new construction areas, as well as cooling of patient care and waiting areas in high humidity areas of the country is not permitted. However, in existing buildings with physical limitations, such as inadequate furred ceiling and shaft spaces and mechanical rooms for equipment and ductwork, use of radiant ceiling panels is permitted. Areas having above mean annual dew point temperature of 40-45 degrees are considered high humidity areas.

2.6.1.2 See VA Master Specifications Section 15835, "RADIANT CEILING PANEL SYSTEMS" and Standard Detail 15705-51.DWG for system capacities and piping connections to radiant panels.

2.6.1.3 The cooling and heating capacity ratings of the radiant ceiling panels, published by different manufacturers, are not based on identical parameters. Further, the published ratings are not certified by any independent testing agency. It is, therefore, incumbent upon the designer to obtain a written approval from at least three manufacturers confirming their ability to supply the radiant panels capable of performing duty conditions as specified in the VA Master specification.

2.6.2 CEILING PANELS

The radiant ceiling panels shall either be modular type 600 mm x 600 mm or 600 mm x 1200 mm (2 ft x 2 ft or 2 ft x 4 ft) size or continuous, wall-to-wall, linear type. The modular panels shall be installed in an "exposed lay-in" type ceiling arrangement. See [Article 3.18](#) for the "concealed snap in" type ceiling system for psychiatric areas. When the active modular heating and cooling radiant panels would occupy approximately 50 percent room ceiling area, the remaining inactive panels shall also be matching metal construction and shall be furnished by the heating and cooling panels manufacturer. With wall-to-wall linear radiant ceiling panels, the remaining suspended ceiling shall be furnished under architectural work. Provide easy access to piping above ceiling.

2.6.3 SPECIAL DESIGN CONSIDERATIONS

2.6.3.1 VENTILATION AIR: Provide outdoor air, properly cooled and heated, for the spaces cooled and heated by the radiant panels to handle the latent load. The ventilation air shall be at least 0.01 Cu M/Min per 0.09 Sq M (0.4 CFM per Sq Ft) of floor area, or more, if required, to meet the exhaust needs or

space latent load. Arrange ventilation air outlets to avoid drafty conditions.

2.6.3.2 CHILLED WATER TEMPERATURE: The temperature of the chilled water entering the radiant ceiling panels shall be at least one degree higher than the space dew point temperature to prevent condensation on the radiant panels. Care should also be taken to eliminate any building leakage. Operable windows without caulking and weather-stripping, and other sources of high humidity shall not be permitted in such spaces.

2.6.4 TYPICAL DESIGN PARAMETERS -- PATIENT BEDROOMS

(a) SUMMER (COOLING MODE):

(1) Indoor Room Conditions: 24 degrees C (76 degrees F) Db, 55 percent RH

(2) Room Dew Point: 15 degrees C (59 degrees F)

(3) Chilled Water Temperature
To Radiant Panels: 16 degrees C (60 degrees F)

(4) Water Temperature Rise: 5 degrees

(5) Mean Water Temperature: 16.5 degrees C (62.5 degrees F)

(b) Winter (Heating Mode):

(1) Indoor Room Conditions: 25 degrees C (78 degrees F) Db, 30 percent RH

(2) Hot Water Temperature
to Radiant Panels: 80 degrees C (180 degrees F)

(c) Minimum Water Flow
through each Radiant Panel: 1.9 L/min (0.5 GPM)

(d) Pipe Size: 3/4-inch

2.7 HEATING SYSTEMS

2.7.1 GENERAL

This section includes requirements for all heating systems using the following mediums:

(a) Hydronic Heat (Hot Water or Hot Glycol Water solution)

(b) Steam

(c) Electricity

(d) Natural Gas or Liquid Propane Gas (LPG)

2.7.2 PERIMETER HEATING

Provide perimeter heating system(s) for the patient bedrooms and other occupied areas, when

(a) The outdoor winter design temperature is -12 degrees C (9 degrees F) and less.

(b) The outdoor winter design temperature is between -12 degrees C (10 degrees F) and -7 degrees C (19 degrees F) and the building thermal envelope does not conform to the requirements outlined in [Article 1.9](#).

2.7.3 DELETION OF PERIMETER HEATING

The perimeter heating can be deleted if the building thermal envelope conforms to the requirements outlined in [Article 1.9](#) and the outdoor temperature is -6.5 degrees C (20 degrees F) and above. See [Article 2.16](#) for emergency power requirements for the heating equipment.

2.7.4 HYDRONIC HEATING

2.7.4.1 GENERAL

(a) Hot water heating system is preferred where extensive runs of piping with multiple terminal units, such as air terminal units (Variable Air Volume or Constant Volume Boxes) and/or perimeter heating devices, are involved.

(b) The minimum pipe size shall be 20 mm (3/4 inch). See [Article 1.3.15.3](#) for the pipe sizing criteria.

2.7.4.2 APPLICATIONS: Depending on the ambient conditions, the hot water or hot glycol water solution can be used as the heating medium either at the air handling units or with the terminal units in the occupied spaces as well as in the miscellaneous spaces listed below:

- (a) Warehouse and Storage Spaces
- (b) Vehicular Storage and Maintenance Spaces
- (c) Attic spaces and Vestibules
- (d) Laundry Facility
- (e) Mechanical Equipment Rooms
- (f) Loading Docks

2.7.4.3 EQUIPMENT

- (a) Unit Heaters and Cabinet Unit Heaters
- (b) Finned Tube Radiation
- (c) Convectors
- (d) Radiant Heating Ceiling Panels
- (e) Heating Coils mounted in air handling units and terminal units, such as fan coil units and VAV/CV boxes
- (g) Air Curtains

2.7.4.4 SYSTEM CONFIGURATION: The heating hot water shall be produced by steam to hot water heat exchanger.

2.7.4.4.1 SYSTEM CAPACITY

(a) For any hydronic heating system with pumping capacity equal to or smaller than 3.7 kW (5.0 HP), provide two heat exchangers and circulating pumps of 100 percent capacity each. One heat exchanger and pump shall act as stand-by.

(b) For any hydronic system with pumping capacity larger than 3.7 kW (5.0 HP), provide two heat exchangers and circulating pumps of 50 percent capacity each. No stand-by equipment is required.

2.7.4.4.2 For reheat and miscellaneous heating applications, such as duct-mounted hot water coils, fan coil units, unit heaters, radiant panels, cabinet unit heaters, heat exchangers, etc., provide one common heating system comprising of two heat exchangers, two circulating pumps, and associated piping. The use of two totally separate and independent heating systems (one for reheat and other for perimeter terminal units) shall be considered only if the use of two systems is proven to be cost effective by the life cycle cost analysis. With a single common heating system care shall be taken to select the lowest hot water temperature and optimum flow rates to compensate for the effect of the hot water temperature reset schedule and to offset the generally constant reheat load of the interior spaces.

2.7.4.4.3 When the heating hot water system is selected for the preheat application, where ambient or mixed air is below freezing, the hot water shall be mixed with glycol to prevent freezing of the coil. This system shall be independent of heating/reheating and shall be designed with two heat exchangers and two pumps similar to the configuration outlined in paragraph 2.7.4.4.2 above.

2.7.4.4.4 For heating hot water systems with pumping capacities of 5.6 kW (7.5 HP) and smaller and with tight space conditions, use in-line centrifugal pumps. For all other systems, use floor mounted, open drive centrifugal pumps. The pump speed, in either case, shall not exceed 1750 RPM.

2.7.4.4.5 Provide a by-pass type cartridge water filter, 1 to 2 percent of total flow capacity. See VA Standard Detail 15705-16 for piping connection.

2.7.4.5 CONTROLS

2.7.4.5.1 Provide a hot water temperature reset schedule to be inversely proportional to the outdoor air temperature. The heating hot water or glycol solution temperature shall not be less than 58 degrees C (140 degrees F). The reset schedule shall be adjustable.

2.7.4.5.2 For a system involving multiple terminal units, the use of variable flow heating system with two-way, straight thru, modulating valves is strongly preferred over a constant flow system involving 3-way, modulating, bypass valves. On systems using two-way valves, care shall be taken to prevent "dead heading" of pumps or no flow conditions by:

(a) Providing at least 15 percent constant flow. This can be achieved by providing three-way, constant flow valves at the farthest end of each circuit.

(b) Constant fixed by-pass at the farthest end of each circuit. An automatic by-pass arrangement based on the pressure differential control may be needed to limit the variable flow operation with pumps "riding the curves".

2.7.4.5.3 For large applications, the use of primary-secondary pumping with variable speed pump control should be evaluated.

2.7.5 STEAM HEATING

2.7.5.1 GENERAL

(a) See [Article 2.9](#) for Steam Piping and Distribution.

(b) Do not use floor-mounted steam radiators for spaces without sub-basements, pipe basements, or crawl spaces to avoid problems with steam condensate return.

(c) See [Article 1.10.3](#) for the required update of the existing steam radiators.

2.7.5.2 APPLICATIONS

2.7.5.2.1 All applications, listed under [paragraph 2.7.4.1\(a\)](#), can be evaluated for steam heating, depending upon the availability of steam at appropriate pressure and the system complexity, if any, involved with the steam condensate return.

2.7.5.2.2 The use of steam shall also be considered for:

(a) Air Handling Units: To preheat the mixed air up to 12.5 to 15 degrees C (55 to 60 degrees F), that is, to match with the cooling coil leaving air temperature.

(b) Heating and Ventilation Units: To heat the outdoor air as determined either by room thermostat or a discharge air temperature sensor.

2.7.5.2.3 See [Article 2.3.1](#) for the type of steam heating coils.

2.7.5.2.4 Extensive use of the duct mounted steam reheat/heating coils shall be avoided to alleviate the problems of

(a) Steam Condensate Return

(b) Lack of space available above the suspended ceiling for installation of steam traps, 300 mm (12 inches) minimum, and for dirt leg additional 150 mm (6 inches).

(c) Trap Maintenance

(d) Objectionable noise due to steam whistling, condensate flow, and water hammering

2.7.5.3 EQUIPMENT

(a) Unit Heaters, Heat Exchangers, and Radiators

(b) Air Handling Units

(c) Heating & Ventilation Units

2.7.5.4 CONTROLS: The steam heating equipment shall be thermostatically controlled. Wherever the steam heating equipment is used in a space, cooled by the mechanical refrigeration, a single thermostat, to avoid the possible occurrence of simultaneous cooling and heating, shall control the space temperature.

2.7.6 ELECTRIC HEATING

2.7.6.1 GENERAL: The electric resistance heating is expensive and its use shall be considered only if the heat generated by the fossil fuels is not available.

2.7.6.2 APPLICATION: The electric heating should be considered for:

(a) Emergency Generator Rooms

- (b) Elevator Machine Rooms
- (c) Electrical Switchgear Rooms

2.7.6.3 EQUIPMENT

- (a) Unit Heaters & Cabinet Unit Heaters
- (b) Convectors
- (c) Radiant Heating Ceiling Panels
- (d) Baseboard Radiation
- (e) Air Curtains
- (f) Unit Mounted Heating Coils
- (g) Air Terminal Units

2.7.6.4 CONTROLS: The electric heat shall be thermostatically controlled. Wherever the electric heating equipment is used in a space, cooled by the mechanical refrigeration, a single thermostat, to avoid the possible occurrence of simultaneous cooling and heating, shall control the space temperature.

2.7.7 GAS HEATING

2.7.7.1 GENERAL: Where natural gas or LPG is readily available, use of the gas fired heating, particularly for the miscellaneous applications listed under [paragraph 2.7.7.2](#) shall be evaluated.

2.7.7.2 EQUIPMENT: The use of the gas heating shall be considered with the following equipment:

- (a) Unit Heaters
- (b) Heating & Ventilation Units
- (c) Roof Top, Self-contained HVAC Units

2.7.7.3 CONTROLS: The heating equipment shall be thermostatically controlled to maintain the design temperatures.

2.8 ETHYLENE GLYCOL-WATER SYSTEMS

2.8.1 GENERAL

2.8.1.1 An ethylene glycol solution of 20 percent by weight has a freezing point of -8 degrees C (18 degrees F). This is the point where first crystals begin to form. Actual freezing into a solid occurs at much lower temperatures (-44 degrees C) (-50 degrees F).

2.8.1.2 Heating applications shall be limited to 20 percent by weight of glycol for preheat and run around coil applications.

2.8.1.3 Where freeze protection is required to -28 degrees C (-20 degrees F) outdoor design conditions and chillers utilizing water temperatures of 3 to 10 degrees C (38 to 50 degrees F), glycol solution shall be limited to 20 percent by weight. Usually a 15 percent by weight glycol solution is adequate for protection to -17 degrees C (0 degrees F) outdoor design condition.

2.8.1.4 Consult manufacturers' capacity rating data for chillers operating with glycol water solution in ambient temperature of -1 degrees C (30 degrees F) or below. Normally glycol solution of 25 to 30 percent by weight should be adequate.

2.8.2 HEAT TRANSFER

2.8.2.1 Table 2-2 below lists effects on heat transfer capacity due to increased viscosity and change in film coefficients of glycol water solution on heat source and chiller units:

Table 2-2 Heat Transfer Capacity Factors For Glycol Solutions

Heat Transfer Capacity Factor				
Solution Wt (Percent)→	15	20	30	40
Steam / Water	0.95	0.92	0.87	0.82
Refrigerant / Water	0.93	0.88	0.80	0.70

2.8.2.2 Effects on terminal units such as heating/cooling coils should be checked with manufacturer's data. The flow rates and pressure drop ratings listed on schedules shall be those for the circulating fluid.

2.8.3 FLOW-HEAD-HORSEPOWER

Effects of ethylene glycol solution on the pump and piping systems.

2.8.3.1 Table below lists properties of the glycol solution.

Table 2-3 Properties of Glycol Solution

Solution/Wt. (Percent)→	15	20	30	40
Freeze point degrees C (degrees F)	-5.5 (22)	-7.8 (18)	-15 (4)	-27 (-17)
Solid point degrees C (degrees F)	-31.7 (-25)	-45 (-50)	-73.3 (-100)	-90 (-130)
Specific Heat (Cp)				
0-40 degrees C (30-40 degrees F)	0.95	0.93	0.88	0.81
82-88 degrees C (180-190 degrees F)	0.98	0.97	0.94	0.90
Specific gravity				
(30-40 degrees F)	1.02	1.03	1.05	1.06

Solution/Wt. (Percent)→	15	20	30	40
(180-190 degrees F)	0.98	0.99	1.00	1.00
Viscosity centipoises (mPa·s)				
30	2.8	3.2	4.0	5.5
40	2.2	2.6	3.2	4.4
180	0.46	0.52	0.60	0.70
190	0.48	0.48	0.58	0.67

2.8.3.2 FLOW-GPM: Use the following correction factors to determine the solution flows. Use this flow in the equipment schedule.

Table 2-4 Ethylene Glycol Solution; Weight Correction Factors

Solution/Wt. (Percent)→	15	20	35	40
0-40 degrees C (30-40 degrees F)	1.03	1.04	1.09	1.16
82-88 degrees C (180-190 degrees F)	1.04	1.04	1.06	1.10

Example: 200 GPM water at 40 ft head and a 40 percent solution wt at 30 degrees F

Flow Rate = 200 x 1.16 = 232 GPM

2.8.3.3 PRESSURE DROP (HEAD): The total head for the solution is as follows. Use this value in the equipment schedule.

(a) The following multiplier factors applied to the head calculated for the water flow will give the increased head due to the increase in solution flow. Note that the corrections for viscosity must also be included in the head calculations. See paragraph (b) below.

Table 2-5 Pump Head Correction Factors For Increased Flow

Solution/Wt (Percent)→	15	20	35	40
0-40 degrees C (30-40 degrees F)	1.06	1.08	1.19	1.35
82-88 degrees C (180-190 degrees F)	1.08	1.08	1.12	1.21

Pressure drop = 40 x 1.35 = 54 feet of water

(b) The following multiplier factors applied to head calculated for the solution flow Item (a), will give the total head for the solution.

Table 2-6 Pump Head Correction Factors For Increased Viscosity

Solution Wt (Percent)→	15	20	30	40
0 degrees C (30 degrees F)	1.12	1.16	1.19	1.23
40 degrees C (40 degrees F)	1.10	1.12	1.16	1.20
82 degrees C (180 degrees F)	0.94	0.94	0.94	0.94
88 degrees F (190 degrees F)	0.94	0.94	0.94	0.94

Total Pressure drop = 54 x 1.23 = 66.4 feet of water

2.8.3.4 HORSEPOWER:

$$\text{BHP} = \frac{\text{GPM Solution} \times \text{Head (feet of solution)} \times \text{Sp. Gr}}{3960 \times \text{Pump Efficiency}}$$

$$= \frac{232 \times 66.4 \times 1.06}{3960 \times 0.69^*} = 5.97 \text{ for 40 percent wt glycol solution}$$

$$\text{BHP} = \frac{200 \times 40 \times 1.00}{3960 \times .70} = 2.89 \text{ for water}$$

* Pump efficiency assumed for the solution is as 0.69. It is reduced only by 1 percent for pump capacity effect.

2.8.3.5 Table 2-7 lists the summary of the results of the example used above.

Table 2-7 Summary Results, Typical Example

Items	Water	Solution {40 percent wt, 0 degrees C (30 degrees F)}
GPM	200.00	232.00
Head, Ft.	40.00	66.40
BHP	2.89	5.97

2.8.3.6 Table 2-8 below lists a summary of correction factors for determining the glycol solution flow, head and break horsepower.

Table 2-8 Summary of Correction Factors For Glycol Solutions

Glycol Wt (Percent) →	15		20		30		40	
	30 (0)	180 (82)	30 (0)	180 (82)	30 (0)	180 (82)	30 (0)	180 (82)
GPM	1.03	1.04	1.04	1.04	1.09	1.06	1.16	1.10
HEAD	1.19	1.02	1.25	1.02	1.42	1.05	1.66	1.14
BHP	1.25	1.04	1.34	1.05	1.63	1.11	2.04	1.27

2.9 STEAM PIPING AND DISTRIBUTION

2.9.1 STEAM GENERATION

See PG-18-10 for STEAM GENERATION SYSTEMS DESIGN MANUAL for Boiler Plants.

2.9.2 OUTDOOR STEAM DISTRIBUTION

For outdoor steam distribution, refer to "OUTSIDE STEAM DISTRIBUTION SYSTEMS DESIGN MANUAL", PG-18-10.

2.9.3 INSIDE STEAM DISTRIBUTION

Steam and Condensate Piping in Buildings Other Than Boiler Plants shall be shown on "MH" drawings:

2.9.3.1 Steam pressure classes for VA projects are as follow:

Table 2-9 Steam Pressure Classifications

Steam Type	Steam (Corresponding) Pressure
Low pressure Steam (LPS)	105 kPa (15 Psig) and below
Medium pressure Steam (MPS)	110 - 406 kPa (16-59 psig)
High pressure Steam (HPS)	413 kPa (60 Psig) and above

2.9.3.2 Steam supplied to the equipment control valves shall be at pressure listed below.

Table 2-10 Equipment Steam Pressure Requirements

Equipment	Pressure
Radiators, Convectors	34 kPa (5 PSIG) 34 kPa (5 PSIG)
Heating coils Heat Exchangers Unit Heaters Domestic Water Heaters Central Humidifiers	206 kPa (30 PSI) maximum (Lower pressures may be used if justified by engineering or economic consideration).

Dietetic Equipment	Refer to PG-18-6
Sterilizers and Washers	Refer to PG-18-6
Laundry Presses and Ironers	860 kPa (125 PSI)
Terminal Humidifiers (Duct Mounted)	105 kPa (15 PSI)

2.9.4 PRESSURE REDUCING VALVES (PRV) AND PRV STATIONS

2.9.4.1 Pressure Services: Provide PRVs for each of the following:

(a) Radiators and Convectors: For the heating system involving radiators and convectors, the steam pressure reduction shall be in two (2) stages: from HPS to 206 kPa (30 Psig), and from 206 kPa (30 Psig) to 34 kPa (5 Psig).

(b) For air handling units and related equipment, that is, heating coils, unit heaters, heat exchangers, central humidifiers, domestic hot water heaters, and dietetic equipment, covert HPS or MPS to 206 kPa (30 Psig). Use local 2nd stage PRV station for equipment, which require less than 206 kPa (30 Psig) steam.

(c) Usually 413 kPa (60 PSIG) steam is required for sterilizing and laboratory equipment. Refer to Equipment Reference Manual, PG-18-6. Use second Stage PRV Station for equipment that requires less than 413 kPa (60 Psig) steam.

2.9.4.2 Size PRV stations for calculated peak demand of building heating, domestic hot water, humidification, and equipment (process) load. For equipment load, use 100 percent steam consumption of the largest single user plus 25 percent steam consumption of all other users.

2.9.4.3 Where a single PRV would exceed 102 mm (4-inch) size or the turn-down ratio (maximum load/minimum load) is greater than 10, provide two PRVs in parallel, approximately 1/3 plus 2/3 with a single by-pass. Where the steam service includes capacity for future expansion, size all PRV station components for the future capacity. Size the PRVs for the present load only. Show globe valves to by-pass the main shut-off valves.

2.9.4.4 Size the PRV by-pass valve and the safety valve according to National Board Inspection Code of the National Board of Boiler and Pressure Vessel Inspectors (Columbus, Ohio). Size the safety valve to handle the maximum flow of the largest PRV or the by-pass. Verify that the by-pass valve capacity does not exceed the capacity of the safety valve.

2.9.4.5 Mechanical Equipment Rooms: The rooms in which PRV stations, pumps, converters, heat exchangers, etc., are located, shall be of suitable size to permit easy access for maintenance. If duplex condensate pump is installed in a pit, the starter, disconnect switch, and alternator are to be located outside the pump pit. See VA Standard Detail 15705-27.

2.9.5 STEAM PIPING

2.9.5.1 Size steam piping according to ASHRAE Guide and Data Books. See Master Specifications, Section 15705, "HVAC PIPING SYSTEMS" for piping materials.

2.9.5.2 Design steam and condensate piping with loops, bends and offsets to allow for thermal expansion and keep stresses within the allowable limits of the piping material. Avoid using expansion joints or ball joints, if possible.

2.9.5.3 Provide roller-type pipe supports where significant horizontal pipe movement will occur due to thermal expansion and spring-type supports where significant vertical movement will occur.

2.9.5.4 The minimum pipe size shall be 25 mm (1-inch) in horizontal runs and 20 mm (3/4-inch) in vertical runs; make any pipe size reduction necessary at the equipment. Long horizontal pipelines shall not be run at the floor. Wherever possible, provide up feed connections through the floor to the equipment.

2.9.5.5 For large steam service, such as the low pressure system for absorbers, provide small globe type warm-up valve, located for convenient operation, to by-pass the main shut-off valve. By-pass valves shall be shown and specified for gate valves 102 mm (4 inches) and larger in steam lines.

2.9.6 STEAM GUN SET

2.9.6.1 A steam gun set (steam, water, detergent) shall be provided in the following areas per VA Standard Detail 15705-21.

- (a) Trash room or trash compaction room
- (b) Manual cart wash, Dietetics
- (c) Manual cart wash, Supply, Processing & Distribution (SPD)

2.9.7 STEAM TRAPS

2.9.7.1 Steam traps on domestic hot water heaters, heating coils and other steam equipment utilizing modulating control valves shall be closed float-thermostatic type with operating pressure range suitable for the maximum steam supply pressure. Trap capacities shall be calculated and shown on the drawings in pounds per hour at one-quarter psig pressure differential across the trap provided the inlet of the traps are 12 inches below the condensate outlet of the equipment. The allowable pressure drop across the trap may be increased if the trap leg is allowed to increase. Steam traps shall be sized based on the maximum condensing rate of the equipment they serve times a safety factor of 1-1/2 or 2. Consult the manufacturers of steam traps.

2.9.7.2 Steam traps on steam line drip points shall be inverted bucket type, with bi-metallic thermal element for air removal, with working pressure range suitable for the maximum line pressure. Trap capacities shall be shown on the drawings in pounds per hour at a specified pressure differential across the trap as follows:

- (a) For steam lines that will be in operation continuously, with infrequent shut downs, drip traps shall be sized for the line radiation loss, in pounds per hour, times three. The trap pressure differential shall be about 80 percent of the line operating pressure.
- (b) For steam lines subjected to frequent warm-up, the trap capacity shall be the amount of steam condensed when the line is warmed up to operating

condition from a cold condition within a period of ten minutes. The trap pressure differential shall be 1.72 kPa (1/4 psig).

2.9.7.3 Steam traps shall be readily available for ease of maintenance.

2.9.8 STEAM CONDENSATE PIPING

2.9.8.1 Condensate from all pieces of steam operated equipment shall be designed to flow by gravity to return to main, flash tank, or condensate pump set. This condition may require trenches in basement floors when pipe space is not provided below basements. Domestic hot water heaters, heat exchangers, and air heating coils shall be mounted high enough to allow gravity condensate flow by gravity. Where sufficient room height is available, provide a mezzanine or platform for easy access to equipment.

2.9.8.2 All condensate shall be returned to the boiler plant by a duplex condensate pump set. Exceptions to this may be necessary when modifying an existing system where a pumped return line to the boiler plant is not available.

2.9.8.3 Use flash tank ahead of condensate pumps on condensate return system from high and medium pressure steam traps. This is to reduce condensate temperature to 91 degrees C (200 degrees F) and to avoid flashing of hot condensate. See VA Standard Detail 15705-26 for Flash Tank Piping.

2.9.9 VENT LINES

Provide an atmospheric vent line of sufficient size and extend it above the roof of the building. Vents from condensate pump and flash tank shall connect to this vent line. Safety valve shall be extended above the roof, to a height of six feet, independent of the other vent line. To avoid long safety valve discharge piping, safety valves may be located close to the terminal point if there is no shut-off valve between the PRV and the safety valve.

2.10 VENTILATING SYSTEMS

2.10.1 GENERAL

Provide ventilation in the following areas where mechanical cooling may not be but heating may be required: See ensuing Article.

- (a) Electrical Equipment Rooms
- (b) Elevator Machine Rooms
- (c) Emergency Generator Rooms
- (d) Gymnasiums
- (e) Mechanical Equipment Rooms
- (f) Motor Vehicle Maintenance/Storage
- (g) Transformer Rooms
- (h) Trash Collection Areas
- (i) Warehouses

2.10.2 OCCUPIED AREAS

2.10.2.1 Gymnasiums

2.10.2.2 Motor Maintenance/Storage Facilities

2.10.2.3 Warehouses

2.10.2.4 SYSTEM CHARACTERISTICS:

(a) The minimum air flow shall be based on 8 air changes per hour. Refer [Article 1.3](#) for the indoor design conditions.

(b) The supply air system shall be comprised of a fan, filters, heating coil, dampers, ductwork and outlets, etc.

(c) The system shall operate continuously during occupied hours.

(d) The system shall be recirculatory type, except for the Maintenance Storage Facility, with 20 percent of the supply air as minimum outdoor air. However, it shall have the capability of admitting 100 percent outdoor air. The return and exhaust air systems shall be designed to match these air flows.

(e) The ventilation and heating shall be thermostatically controlled. The night set back temperature of 10 degrees C (50 degrees F) shall be maintained by cycling the ventilation unit (no outdoor air, 100 percent recirculation).

(f) The motor maintenance storage facility shall be 100 percent exhaust of the supply air during occupied hours. The exhaust griller shall be located at 150 mm (6 inches) above the floor level.

2.10.3 UNOCCUPIED AREAS

2.10.3.1 Electrical Equipment Rooms (Without Heat Producing Equipment)

2.10.3.2 Mechanical Equipment Rooms

2.10.3.3 Telephone/Signal Rooms

2.10.3.4 SYSTEM CHARACTERISTICS:

(a) The ventilation system shall have thermostatically controlled exhaust fan(s) and shall run intermittently in response to a rise in the space temperature above an adjustable set value of 26 degrees C (80 degrees F). The system shall also be capable of operating manually.

(b) The minimum system capacity shall be as follows:

Table 2-11 Minimum Ventilation Air Changes/Hr

Type of Rooms	Air Changes/Hr
Electrical Equipment Rooms	8
Mechanical Equipment Rooms without steam service components, such as, PRV station, flash tank, heat exchangers, condensate pumps, etc.	8
Mechanical Equipment Rooms with steam service components	20
Chiller Plants	See Article 2.12

(c) The unfiltered outdoor air shall be directly admitted to the above rooms via motorized dampers, connected to the outdoor air louvers. The exhaust fans ducted or otherwise, shall discharge the room air outdoors. Locate the intake and exhaust air louvers as far as possible and, if possible, at diagonally opposite ends, to ensure complete sweep of the air.

(d) Provide heating in these rooms to maintain the design temperature noted in [Article 1.3](#), by thermostatically controlled terminal heaters, such as unit heaters. The sequence of operation shall be such that the heating system and ventilation system will not operate at the same time.

2.10.4 TRASH COLLECTION AREAS

2.10.4.1 GENERAL: Provide a minimum of 10 air changes per hour of exhaust air and maintain negative pressure in the room.

2.10.4.2 SYSTEM CHARACTERISTICS

(a) The ventilation system shall run continuously.

(b) The ventilation system for this area can be connected to the building general exhaust system if the location of the trash collection area permits such a tie-up. Alternately, provide a dedicated exhaust system.

(c) Depending upon the architectural layout, the ventilation system may use the building air fully or partially as a make-up for the exhaust. For a fully closed trash collection room, the use of the corridor air as a make-up is not permitted.

(d) Provide thermostatically controlled heat to maintain 10 degrees C (50 degrees F) in winter in the trash collection area.

2.10.5 ELEVATOR MACHINE ROOMS

2.10.5.1 GENERAL

Following design conditions must be maintained in the machine rooms for safe operation of elevators.

Summer: 36 degrees C (94 degrees F) or lower

Winter: 10 degrees C (50 degrees F)

2.10.5.2 DESIGN CONSIDERATIONS

Provide a dedicated, thermostatically controlled, mechanical ventilation or recirculatory mechanical cooling system to maintain the indoor design conditions. The mechanical ventilation system shall be used only at those locations where the summer outdoor design temperatures (0.4 percent ASHRAE Weather Chart) does not exceed 26 degrees C (80 degrees F). The summer and winter indoor temperatures settings shall be such that simultaneous heating and cooling shall be avoided at any given time. For a specific application, should it become necessary to maintain lower space temperature and humidity for the microprocessor based electronic controls, provide a dedicated cooling unit (DX or chilled water). Heating may be provided by 4-pipe fan coil units along w/cooling or separately by unit heaters. See [Article 2.12](#) for the dedicated refrigeration system. Coordinate with the VA and/or the elevator equipment manufacturer.

2.10.5.3 CODE COMPLIANCE

2.10.5.3.1 Mechanical equipment installations in elevator machine rooms shall conform to the National Electric Code. It conforms to rule 102.2 of American National Standard Safety Code for Elevators ANSI/ASME A17.1-1985, which says, "Pipes or ducts conveying gases, vapors, or liquids, not used in connection with the operation of the elevator, shall not be installed in hoistway, or machine room."

Exceptions:

(a) Steam and hot water pipes may be installed in hoistways or machine rooms for the purpose of heating these areas only.

(1) Heating pipes shall convey only low pressure steam 35 kPa (5 PSIG) temperature or less or hot water at 100 degrees C (212 degrees F) or less.

(2) All risers and return pipes shall be located outside the hoistway.

(3) Traps and shut-off valves shall be provided in accessible locations outside the hoistway.

(b) Ducts for heating, cooling, and ventilating may be installed in the machine room.

2.10.5.3.2 Life Safety Code NFPA 101 requires that when stand-by power is connected to the elevator, the machine room ventilation or air-conditioning shall also be connected to stand-by power; exception: existing elevators.

2.10.5.4 HEAT EMISSION

Heat emission data for the elevator equipment in the machine room shall be obtained from an elevator manufacturer. Heat emitted includes that from the elevator hoisting motors, motor-generator sets, machine brake coils and all elevator control equipment located in the machine room(s). Use the following as preliminary guide for calculating heat load.

(a) For variable voltage DC with motor-generator (MG) set:

$$\text{BTU/Hr/Car} = \text{Rated Elevator Motor HP} \times 0.3 \times 2544$$

This heat release shall be divided, if appropriate, 60 percent for MG room and 40 percent for machine and controller room.

(b) Table 2-12 below lists Heat Dissipation Data for elevator equipment based on electronic controls, 1.5 m/s (300 fpm) speed, and normal acceleration, are as follows:

Table 2-12 Heat Dissipation Data for Elevator Equipment

Capacity kg (lb)	kW (HP)	WATTS (BTU/hr) per Car
1135 (2500)	18.7 (25)	3225 (11,000)
1360 (3000)	18.7 (25)	3370 (11,500)
1590 (3500)	22.4 (30)	3516 (12,000)
1815 (4000)	30 (40)	4395 (15,000)

2.10.6 EMERGENCY GENERATOR ROOM

2.10.6.1 GENERAL

(a) Indoor Design Conditions:

Summer: 42 degrees C (110 degrees F)

Winter: 4 degrees C (40 degrees F)

(b) Provide heat and ventilation in emergency generator building or room when the engine-generator set is idle and operating as well. See VA Standard Detail 15900-17 for control of the heating and ventilating equipment. Analyze noise levels and provide attenuation, if necessary. Electric unit heater, thermostatically controlled shall maintain 15 degrees C (60 degrees F) minimum space temperature when the generator is not in operation. Extra care should be taken in sizing the unit heater capacity particularly when the radiator and fan are installed in the generator room. The cracks in the exterior walls, which could be caused due to the installation of large louvers and the louvers not fully shut in closed position, could create heavy infiltration of cold air.

2.10.6.2 ENGINE-GENERATOR OFF

Provide a thermostatically controlled ventilation exhaust fan to deliver 15 air changes per hour.

2.10.6.3 ENGINE-GENERATOR OPERATING

The air intakes and exhaust outlets shall be located so air does not short circuit and air shall pass over the engine-generator set before it is exhausted. Additional ventilation shall be provided as required to reject the heat from the engine-generator set, muffler (if installed in room) and exhaust pipe. See electrical specification Section 156208, "ENGINE GENERATORS" for the muffler and exhaust piping, which is to be covered with calcium silicate insulation.

2.10.6.4 RADIATOR AND FAN TOGETHER

When the radiator and fan for the engine-generator are installed in the same room as the engine-generator, provide the following:

(a) A sheet metal plenum, with a flexible connection, between radiator and exhaust louvers.

(b) Two opposed blade power operated dampers, one (normally open) located at the exhaust louver and one (normally closed) located in the sheet metal plenum wall to heat room with waste heat when engine is running. A room thermostat shall modulate the two dampers to maintain a minimum room temperature of 15 degrees C (60 degrees F).

(c) Supply air intake shall be large enough to provide make-up air for the radiator exhaust, and the room ventilation. The intake shall have a normally open motor operated damper. Damper shall open whenever the generator or room ventilation fan is energized.

(d) Size the exhaust fan so the combined static pressure loss through the intake and exhaust louvers, and motor operated dampers does not exceed 63 Pa (0.25 inch of water).

2.10.6.5 RADIATOR AND FAN REMOTE

When the radiator and fan are installed remote to the engine-generator, do the following:

2.10.6.5.1 Provide two exhaust fans to ensure the following:

(a) Room Ventilation: The room ventilation fan (capacity: 15 Air Changes/hr.) shall operate either manually or thermostatically when the space temperature exceeds 29 degrees C (85 degrees F).

(b) An additional exhaust fan shall operate only when the emergency generator is running and the space temperature exceeds 29 degrees C (85 degrees F)

2.10.6.5.2 Supply air intake shall be large enough to provide make-up air for the two exhaust fans and the combustion air. The intake shall have a normally open motor operated damper and shall open whenever generator or either exhaust fan is energized.

2.10.6.5.3 Louvers shall have drainable type blades and shall be furnished under architectural specifications. Louvers shall be sized to provide the required air for the two exhaust fans. See [Article 1.8](#) for additional information.

2.10.7 TRANSFORMER ROOMS (VAULTS) AND ELECTRIC CLOSETS

2.10.7.1 GENERAL

Maximum indoor temperatures of 39 degrees C (104 degrees F) shall be maintained in transformer rooms (Vaults) and electrical closets with dry type transformers. Small electrical closets without any heat producing devices, such as, dry type transformers, need not be cooled or ventilated. Any pipe or duct system foreign to the electrical installation shall not pass through an electrical room or a closet.

2.10.7.2 HVAC SYSTEMS

To prevent excessive heat build up in transformer rooms, provide a dedicated, thermostatically controlled, mechanical ventilation or cooling system. The requirement of a dedicated system can be waived if the room is served by a building HVAC system that operates 24 hours a day. Design the ventilation system to maintain the space temperature using the outdoor summer design temperature 1 percent value listed in the ASHRAE Weather Data.

2.10.7.3 INTERNAL HEAT GAIN

The internal heat gain to the space due to different type of transformers should be based on the following:

(a) Dry Type Transformers: 35 W (120 BTUH) Per KVA for 30 KVA through 112 KVA.

(b) Liquid Type Transformers: 15 W (50 BTUH) Per KVA for 225 KVA and larger sizes.

2.10.7.4 VAULT CONSTRUCTION

For a non-sprinkled, oil-insulated transformer vault, the floor, the ceiling, and the interior walls usually have a 3-hour fire rating and require a 3-hour fire door in any duct penetration. Exterior walls, regardless of fire rating, require 1 1/2 hour fire damper in penetrations if there is a window opening above within 3 m (10 feet). With a sprinkled vault, the requirement for a fire damper is waived.

2.11 EXHAUST SYSTEMS

2.11.1 GENERAL EXHAUST SYSTEMS

The exhaust systems shall be conventional, low pressure, low velocity type serving toilets, day rooms, janitor closets, canopy type (A, B, and C) hoods, soiled utility rooms, dark rooms, trash rooms, silver recovery rooms, maintenance garages, etc. The exhaust systems shall also include areas, with 100 percent exhaust of the supply air, such as surgical suites, SPD areas (less dedicated exhaust for Ethylene Oxide (ETO) Sterilizers), laboratories (less special fume hoods), kitchen (less range hood), and animal research (less special fume hoods).

2.11.1.1 In general, each supply air system shall have a corresponding general exhaust system to comply with outdoor air requirements. The exhaust system may or may not be interlocked with supply air system. It shall shut down when supply air system shuts down during unoccupied hours to conserve energy, except exhaust fans shall continue to run when smoke is detected in the areas served by these fans. See Standard Detail 15900-11B.

2.11.1.2 Individual toilets and janitor closets, in general, draw make-up air (exhaust air) from the corridors by using undercuts and/or door grilles. Exhaust air shall not be drawn from the corridors through any storage room.

2.11.2 SPECIAL EXHAUST SYSTEMS

2.11.2.1 General

(a) The special exhaust system includes dedicated exhaust systems for critical areas, such as isolation rooms, laboratories, SPD, autopsy, etc. Each dedicated exhaust system shall have its own exhaust fan and ductwork. It shall not be connected to the general building exhaust system or another or another exhaust system.

(b) Each dedicated system has its unique set of requirements for air quantity, filtration, construction of materials, type of discharge, controls, emergency power, hours of operation, etc.

2.11.2.2 To be in compliance with NFPA 90A, ducts connected to the special exhaust systems, noted below, are hazardous and shall not be housed in the same shaft, carrying environmental supply, return, and exhaust ducts.

- (a) Laboratory Hood Exhaust Systems
- (b) ETO-Ethylene Oxide Sterilizers Exhaust Systems
- (c) Grease-Laden Kitchen Hood Exhaust Systems
- (d) Ortho/Prosthetic Laboratory Exhaust
- (e) Battery Charging Rooms

2.11.2.3 All other ducts carrying make-up air, connected to special exhaust systems, may be installed in the same shaft, which carry environmental supply and/or return ducts.

2.11.2.4 Exhaust fans shall be located close to the discharge air to maintain a negative air pressure in the exhaust ductwork inside the building.

2.11.3 LABORATORY HOOD EXHAUST SYSTEMS

2.11.3.1 GENERAL: The fume hoods and biological safety cabinets for the laboratories and research services require dedicated exhaust systems. While the type of exhaust system would depend upon the hood characteristics, the following features shall be incorporated into the design to avoid excessive noise levels and ensure accurate air balancing. Room noise criteria for laboratories are NC 45.

- (a) The ventilation system for the fume hood exhaust shall conform to the OSHA (Occupational Safety and Health Act), Regulation 29 CFR, Part 1910. The exhaust shall be continuously monitored and an alarm system (local audible and visible alarm, and an alarm at the central engineering control center (ECC), if any, shall be provided for each fume hood and biological safety cabinet.
- (b) The exhaust fans shall be selected to operate at low tip speed (approximately at half the maximum permissible tip speed) and maximum static efficiency. Provide fan selection data on a performance curve. Ensure that the fan discharge is directed vertically upward and the discharge velocity of 15.3 m/s (4,000 fpm) is maintained. See VA Standard Detail 15822-2 for stack installation. Minimum height of stack shall be 7-feet high as per ASHRAE.
- (c) Keep air velocity through the exhaust ducts within the ASHRAE recommended range of 5.1 to 6.12 m/s (1000 to 1200 fpm).
- (d) Select backward inclined or forward curved blade fans.
- (e) Perform sound analysis for each exhaust fan and provide sound attenuation, if required. Use prefabricated sound attenuators or lined ductwork.
- (f) To ensure design airflow, a pressure independent, factory-set, field-adjustable, automatic airflow control shall be provided for each fume hood and a biological safety cabinet.

2.11.3.2 RADIOISOTOPE HOODS (H3)

(a) Provide a dedicated exhaust system for each H3 type hood

(b) The exhaust air quantities and pressure drops are listed below in Table 2-13:

Table 2-13 H3 Hood Exhaust Air Requirements

Size mm (Inches)	Exhaust Cu M/Min (CFM)	Pressure Drop Pa (Inches of Water)
1200 (48)	24.5 (875)	93 (0.375)
1500 (60)	31.5 (1125)	93 (0.375)
1800 (72)	38.5 (1375)	93 (0.375)

(c) Provide a HEPA filter in exhaust air duct prior to discharge at or above the highest point of the building.

(d) Provide an alternate room exhausts air connection so exhaust air may be drawn from the room grille when the hood is not in operation. Provide motorized dampers in each branch and an airflow control valve to ensure constant static pressure in each branch. See VA Standard Detail 15900-8. The minimum static pressure drop to operate the valve shall not exceed 93 Pa (0.375 Inches of Water).

(e) The ductwork shall be all welded stainless steel.

(f) See [Article 2.16](#) for emergency power requirements.

2.11.3.3 FUME HOODS H7/H13: H7 and H13 hoods have identical requirements with the exception of the make-up air system. The H7 hoods use all room air as the make-up air for exhaust; the H13 hoods use 60 percent auxiliary make-up air directly ducted to the hoods and remaining 40 percent air comes from the room for their exhaust needs.

(a) Provide a dedicated exhaust system to serve not more than four H7 or H13 hoods.

(b) The exhaust air quantities) and pressure drops for H7 and H13 hoods are listed below in Table 2-14.

Table 2-14 H7/H13 Hood Exhaust Air Requirements

H7 Hoods		H13 Hoods			Pressure Drop	
Size mm (Inches)	Exhaust Cu M/Min (CFM)	Room Cu M/Min (CFM)	Auxiliary Cu M/Min (CFM)	Total Cu M/Min (CFM)	ExhaustH 7/H13 Cu M/Min (CFM)	Make-up H13 ONLY Cu M/Min (CFM)
900 (36)	19 (625)	7 (250)	11 (375)	18 (625)	89 (0.36)	7 (0.03)
1200 (48)	25 (875)	10 (350)	15 (525)	25 (875)	75 (0.30)	17 (0.07)
1500 (60)	32 (1125)	13 (450)	19 (675)	32 (1125)	89 (0.32)	55 (0.22)
1800 (72)	39 (1375)	15 (550)	23 (825)	39 (1375)	60 (0.24)	82 (0.33)

H7 Hoods		H13 Hoods			Pressure Drop	
Size mm (Inches)	Exhaust Cu M/Min (CFM)	Room Cu M/Min (CFM)	Auxiliary Cu M/Min (CFM)	Total Cu M/Min (CFM)	ExhaustH 7/H13 Cu M/Min (CFM)	Make-up H13 ONLY Cu M/Min (CFM)
2400 (96)	53 (1875)	21 (750)	32 (1125)	53 (1875)	100 (0.40)	139 (0.56)

(c) The auxiliary make-up air shall be filtered and heated to room temperature by a central make-up air unit. See [Paragraph 2.3.2](#) for filtration requirements.

(d) The designer shall compare the two schemes involving all room air and the combination of auxiliary make-up air and room air and make recommendation to the VA before the selection of the hood.

(e) The ductwork shall be stainless steel or optional PVC coated galvanized steel with spark-proof construction exhaust fan and explosion proof motor.

(f) See [Article 2.16](#) for emergency power requirements.

2.11.3.4 BIOLOGICAL SAFETY CABINETS (HOODS) H12: A biological safety cabinet protects the researcher, and in some configurations, the research materials as well. Biological safety cabinets are sometimes called safety cabinets, ventilated safety cabinets and glove boxes. These safety cabinets are categorized into three classes and six groups. The National Sanitation Foundation (NSF), Standard 49, has divided the Biological Safety Cabinets (BSCs) into Class I, II, and III Cabinets. Class II Cabinets are of four different types, namely A, B1, B2, and B3. These hoods are available in two sizes (nominal): 1200 mm (4 ft) and 1800 mm (6 ft). Class II offers personal, product, and environmental protection compared to the limited protection offered by Class I and are, therefore, more in use. Class III Cabinets are rarely used. All Class II Cabinets require HEPA filters for the downflow and exhaust air system.

2.11.3.4.1 Class I: Similar to chemical fume hoods, no research material protection, 100 percent exhaust through a HEPA filter. Provide a dedicated exhaust system for each B1 or B2 hood, i.e. each hood must have its own independent exhaust fan and duct work. The ductwork shall be stainless steel or optional PVC coated galvanized steel.

2.11.3.4.2 Class II: Biological Safety Cabinet configurations are as per ASHRAE Applications Handbook, 1999.

(a) Type A: 70 percent recirculation within the cabinet, 30 percent exhaust through a HEPA filter, common plenum configuration, can be recirculated into the laboratory.

(b) Type B1: 30 percent recirculation within the cabinet, 70 percent exhaust through a HEPA filter, separate plenum configuration, must be exhausted to the outside.

(c) Type B2: 100 percent exhaust through a HEPA filter to the outside.

(d) Type B3: 70 percent recirculation within the cabinet, 30 percent exhaust through a HEPA filter, common plenum configuration, must be exhausted to the outside.

(e) Provide a dedicated exhaust system for each Type B1, B2 & B3 safety cabinets.

(f) The exhaust air quantities and pressure drops for class II safety cabinets Type A & Type B3 are listed below in Table 2-15, and Table 2-16. Table 2-15 is based on direct connection to exhaust ductwork, and table 2-16 is based on indirect connection to exhaust ductwork. The exhaust air for Type A and B3 Cabinets may be connected to the general exhaust system with indirect connection or a direct connection. The indirect connection involves an air gap between the safety cabinet and the exhaust duct. See Standard Detail 15840-20. The exhaust system must pull more air than the exhaust air through the cabinet to make-up airflow in through the gap. A hard connection can also be used to minimize air exhaust from the laboratory, provided the exhaust fan operates continuously. Type B1 and B2 Cabinets require direct connections and should run continuously.

**Table 2-15 Direct Connection (Type A & B3 Biological Safety Cabinets)-
Exhaust Air Requirements**

Nominal Size mm (Ft)	Exhaust Air Cu M/Min CFM)	Pressure Drop Pa (Inches of Water)
1200 (4)	10 (330)	35 (0.14)
1800 (6)	15 (510)	35 (0.14)

**Table 2-16 Indirect Connection (Type A & B3 Biological Safety Cabinet)-
Exhaust Air Requirements**

Nominal Size mm (FT)	Exhaust Air Cu M/Min CFM)	Pressure Drop Pa (Inches of water)
1200 (4)	14 (490)	25 (0.10)
1800 (6)	20(700)	25 (0.10)

(g) The exhaust air quantities and pressure drops for type B1 and B2 and Class II cabinets are listed below:

Table 2-17 H12 Cabinet (Types B1 and B2) Exhaust Air Requirements

Type	Size mm (FT)	Exhaust Air Cu M/Min (CFM)	Pressure Drop Pa (Inches of Water)
B1	1200 (4)	8 (270)	249 (1.0)
B1	1800 (6)	12 (410)	249 (1.0)
B2	1200 (4)	20 (730)	523 (2.0)
B2	1800 (6)	32 (1150)	523 (2.0)

(h) Notes:

(1) Class II, type B1 and B2 safety cabinets come with two sets of HEPA filters, one for supply within the cabinet, and the other for exhaust from the cabinet. The pressure drops include friction loss through clean exhaust HEPA filters (not the supply HEPA filter within the cabinet as internal blower takes care of this filter) and transition fitting on exhaust side.

With type B1 hood, the exhaust filter is within the hood casing; the mounting is external with type B2 hood. Interlock the internal blower and external blowers. Coordinate the filter height above B2 Hood in the case of B2 safety cabinet with other disciplines.

(2) Add pressure drop for future loading of HEPA filters and duct work to the pressure drops shown above for determining static pressures of exhaust fans.

(3) Provide an airflow control valve in the exhaust air stream to ensure constant airflow through the exhaust air system.

(4) Coordinate the following accessories with the hood manufacturer.

(4.1) Provide an airtight damper on the exhaust side to isolate the hood for service and maintenance.

(4.2) Provide air monitoring Device and provision for sound and visible alarm at the hood and at the central ECC in the event the flow varies more than plus or minus 5 percent of the normal value.

(4.3) Provide an airflow switch to sound an alarm in the event of an interruption in exhaust fan operation.

(4.4) See [Article 2.16](#) for the emergency power requirements.

2.11.3.4.3 Class III - Special research application. 100 percent exhaust through HEPA filters to outdoors.

2.11.3.5 PERCHLORIC ACID HOODS (H14): These hoods require dedicated exhaust systems with the following specific requirements:

2.11.3.5.1 The exhaust air quantities and pressure drops for H14 hoods are listed below:

Table 2-18 H14 Hood Exhaust Air Requirements

Size mm (Inches)	Exhaust Air Cu M/Min (CFM)	Pressure Drop Pa (Inches of Water)
1200 (48)	29 (1030)	156 (0.625)
1500 (60)	38 (1355)	125 (0.50)
1800 (72)	47 (1680)	187 (0.75)
2400 (96)	66 (2355)	187 (0.75)

2.11.3.5.2 Ductwork shall be stainless steel (type 316) welded construction. Fan shall be acid resistant metallic or metallic covered with inorganic (polyurethane) coating, and explosion proof motor.

2.11.3.5.3 Ductwork shall be short, straight, with minimum horizontal runs, manifolds and sharp turns. The exhaust duct shall terminate by using a vertical discharge, which shall extend well above the roof eddy zone.

2.11.3.5.4 Coordinate cold-water make-up connections and electrical power requirements for heat tracing with other trades for the wash down cycle.

2.11.3.5.5 See [Article 2.16](#) for emergency power requirements.

2.11.3.5.6 Provide visible and audible alarms, local as well as at Engineering Control Center (ECC). Alarms shall indicate status and failure.

2.11.4 AUTOPSY AND MORGUE EXHAUST SYSTEMS

Provide a dedicated exhaust system for the Autopsy Suite with the following features:

- (a) The exhaust fan shall be located at or near the roof with the fan discharging above the highest point of the building.
- (b) Provide a HEPA filter in the exhaust air duct at or near the exhaust fan. See VA Standard Detail 15900-10.
- (c) Provide a pressure-independent, constant volume, airflow control valve in the exhaust air stream to maintain constant airflow with the varying system resistance.
- (d) Provide a canopy (Type A) exhaust hood above the top of the dissecting tables (HW 801 and HW 802). Exhaust air quantity shall not exceed 0.5 m/s (100 fpm) of the hood face area.
- (e) Provide down draft exhaust for HW 800 type dissecting tables. Coordinate exhaust air quantity and use of exhaust plenum and adjustable damper with the equipment manufacturer.
- (f) In Gross Specimen Storage Room, locate ceiling exhaust air registers above the sink counter area to exhaust chemical fumes.
- (g) Exhaust room air near each autopsy table by placing two wall registers approximately 178 mm (7 inches) above finished floor.
- (h) Exhaust approximately 1.5 Cu M/Min (50 CFM) from the cold room (mortuary refrigerator) when the room light is on. Provide an interlock of the exhaust damper with the cold room door switch. See HVAC Standard Detail 15900-10.

2.11.5 ETHYLENE OXIDE (ETO) STERILIZER EXHAUST SYSTEMS

Provide a dedicated exhaust system to ventilate ETO sterilizer equipment, mechanical chase, floor drains, deaeration units, and cylinder storage area. The exhaust system shall be separate from the general exhaust system serving SPD area. ETO exhaust systems shall comply with state and local code requirements and ensure that the systems are designed to comply with these requirements as well. See [Article 3.20](#) for specific requirements.

2.11.6. ISOLATION ROOM EXHAUST SYSTEMS

2.11.6.1 GENERAL: In [Article 1.3](#), [Table 1-2](#), specific applications of the isolation rooms are listed.

2.11.6.2 Negative Pressure Rooms: These rooms are required to remain under negative pressure at all times with respect to the adjoining spaces and anteroom, if required. This is to protect the adjoining spaces from the patients.

2.11.6.3 Positive Pressure Rooms: These rooms are required to maintain under positive pressure at all times with respect to the adjoining spaces and anteroom, if required. This is to protect the patients from the adjoining spaces.

2.11.6.4 The Isolation Suite shall have a dedicated exhaust system comprising of a roof mounted exhaust fan, HEPA filter, and pressure-independent, constant volume, air flow control and balancing device.

2.11.6.5 Reverse Isolation Capability: Provide separate negative and positive pressure Isolation Rooms. Switchable isolation rooms that can be set to function with either positive or negative pressure are not permitted, per ASHRAE and CDC.

2.11.6.4 For air changes per hour and other design parameters See [Article 1.3](#), and for emergency power requirements see [Article 2.16](#).

2.11.7 KITCHEN EXHAUST SYSTEMS

All kitchen hoods are furnished as dietetic equipment, including the canopy hood over pot washing. See [Article 3.12](#) for specific requirements.

2.11.8 NURSE SERVER CABINET EXHAUST

Approximately 0.85 Cu M/Min (30 CFM) should be exhausted from the "soiled" unit server cabinet. See HVAC Standard Detail 15840.19. There is one "soiled" unit per bank of two or three servers. Coordinate with the architectural drawings to determine the exact number of "soiled" units.

2.11.9 ORTHOTIC/PROSTHETIC LABORATORIES EXHAUST

See [Article 3.13.5](#) for specific requirements.

2.11.10 BATTERY CHARGING AREAS

See [Article 4.1](#) for specific requirements.

2.11.11 ANIMAL RESEARCH FACILITY

See [Article 3.3](#) for specific requirements, including "wet exhaust" for cage washers.

2.11.12 MAINTENANCE GARAGES

(a) Exhaust Systems for maintenance garages shall be designed and constructed in accordance with the requirements of NFPA 88B for Repair Garages.

(b) Provide a mechanical exhaust system with a hand-off-automatic (H-O-A) switch to run the exhaust system as required. The exhaust system shall have a minimum capacity of 6 air changes per hour. The exhaust air outlets shall be located close to floor level with the bottom of the inlet 300 mm (12 inches) above the floor.

(c) Each motor-vehicle service stall shall have one flexible, retractable exhaust tube, equipped with adapter, connected to the mechanical exhaust system duct.

(d) The make-up air shall match the exhaust air quantity and shall be supplied as follows:

(1) Winter: Make-up air units with filters and heating coils.

(2) Summer: The make-up air may be brought into the garage through open doors and windows.

(3) During unoccupied hours, the garage shall be heated in 100 percent recirculation mode to maintain a minimum of 5 degrees C (50 degrees F).

2.12 REFRIGERATION SYSTEMS FOR AIR CONDITIONING

(See [Article 4.11](#) for Walk-in Refrigerators)

2.12.1 GENERAL

2.12.1.1 SYSTEM TYPES: The refrigeration systems shall be either chilled water or direct expansion (DX) type. See paragraph 2.12.6 for restrictions on use of DX system for high humidity areas of the country.

(a) Chilled Water System: Chilled water systems generally use air-cooled or water-cooled chillers or absorption types. Absorption chillers could also be used, if it saves energy. Electric chillers come with a variety of compressors - centrifugal, scroll or reciprocating type. Reciprocating chillers, however, are phasing out slowly.

(b) DX System: These systems use refrigerant throughout between compressor and cooling coils. Screw, scroll and reciprocating compressors are generally used for this application.

2.12.1.2 SYSTEM SELECTION: The selection of a specific refrigeration system requires careful analysis. The following parameters influence the selection:

(a) Life Cycle Cost Analysis of different chilled water systems.

(b) System Capacity, kW (Tons of Refrigeration).

(c) System Application, Examples: Surgical Suites or Regional Office Buildings.

(d) New System or Addition to Existing System.

2.12.1.3 REFRIGERANT SELECTION: The refrigerant shall be fully compatible with all local, state, and federal regulations. The refrigeration equipment selection shall be based on the new EPA approved hydrochlorofluoro-carbon refrigerants, such as, HCFC 123, HFC 134a, and HCFC 22. The latest versions of ASHRAE Standards 15 and 34 shall be followed to ensure its full compliance.

(a) Provide adequate ventilation of the mechanical equipment rooms, and make provisions for emergency shut down of equipment.

(b) Provide refrigerant vapor detectors and monitors, and alarms local as well as at ECC. A minimum of two self-contained breathing apparatus shall also be provided, one inside and one outside the mechanical equipment room.

(c) Low pressure chillers shall be vented to outdoors.

2.12.2 CENTRAL CHILLED WATER PLANT

Design of a central chilled water plant shall be in accordance with the following criteria:

2.12.2.1 NUMBER OF CHILLERS: The central chilled water plant shall comprise of at least two chillers, unless the system is to be cross connected to an existing chilled water plant. In that case, a single chiller may be used. The

chillers shall be identical in size and design, except for the following considerations:

(a) Part Load Conditions: If the anticipated part load conditions justify the use of uneven sizes. The designer shall prepare the necessary cooling load profile demonstrating the need for doing so.

(b) Operating Costs: Do a life cycle cost analysis of the following chillers. Based on the favorable results for energy consumption and/or electrical demand charges, a selection of the chiller plant shall be made.

- (1) All electric chillers
- (2) All absorption chillers
- (3) Combination of electric and absorption chillers

2.12.2.2 CHILLER CAPACITY: The maximum capacity of a single chiller unit shall not exceed 3520 kW (1,000 tons) for a central chiller plant. The cooling loads for the surgery suites ([Paragraph 2.12.7](#)) and the animal research areas ([Paragraph 2.12.8](#)) shall not be included in the central plant capacity computations. These both areas shall have their own dedicated chillers.

2.12.2.3 CHILLER PERFORMANCE: The electric, water-cooled, centrifugal and rotary-screw chillers shall be scheduled on drawings in accordance with the ARI Standard 550/590-98 for the lowest full load KW/ton which can be met by at least three manufacturers. Executive Order 13123 and FAR Section 23.704 requires that products be purchased in the upper 25 percent of energy efficiency. Accordingly, DOE recommends following chiller efficiencies, which are based on standard reference conditions, specified in ARI Standard 550/590-98. The designer however, shall document the values selected with calculations, manufacturer's selection data, and any other relevant information for actual (non-standard) design conditions for a specific project and the efficiencies could vary from values shown below.

Table 2-19 Chiller Efficiencies for Standard ARI Conditions

Chiller Type	Full Load-kW/Ton	IPLV-kW/Ton
Centrifugal 150-299 Tons	0.59 or Less	0.52 or Less
Centrifugal 300-2000 Tons	0.56 or Less	0.44 or Less
Rotary-Screw 150 Tons or Greater	0.64 or Less	0.49 or Less

2.12.2.4 STANDBY EQUIPMENT

(a) Chillers: Standby refrigeration equipment or arbitrary safety margin as a spare capacity is not required. See [Article 1.3.15](#) for air handling capacity. Chiller(s) shall be sized based on this capacity.

(b) Pumps: When two chillers are used to handle the total cooling load, one condenser water and one chilled water pump shall be provided to act as standby. When three or more chillers are used, no standby pumps will be required.

2.12.2.5 ADDITIONAL DESIGN CONSIDERATIONS

(a) New Construction: A designated reserve space shall be provided, and shown on the drawings, for a future chiller equal in size to the largest machine being furnished. The space planning shall also include space for circulating pumps, cooling tower, electrical starter, etc. associated with future chiller. The chilled and condenser water mains and the chilled water distribution loop shall be sized, valved, and arranged to accommodate the future chiller.

(b) Chiller/Accessories Arrangement:

(1) The piping arrangement shall be such that each chiller shall have a dedicated condenser water pump, cooling tower fan and a primary chilled water pump. When the chiller is not in operation, its dedicated condenser and chilled water pumps and the cooling tower fan shall also be inoperative.

(2) Chilled water and condenser water circuits shall be piped for complete functional flexibility. Provide cross connections for the chilled water pumps and condenser water pumps, suctions and discharges, and condenser inlets and outlets, and cooling tower cells to increase flexibility. Provide automatic on/off valves, where necessary, to avoid pumping through an inoperative chiller and cooling tower. Investigate the need to provide primary/secondary piping-pumping arrangement as described below.

(3) Primary/Secondary Arrangement: The chilled water flow through the evaporators shall be kept constant. The chilled water flow through the cooling coils, however, shall be variable with automatic, two-way, modulating control valves controlling the flow. A primary/secondary piping arrangement, shown in [Central Chilled Water Plant Flow Diagram 2.12.3](#), shall be used to ensure hydronic separation between primary and secondary loops.

(4) Tertiary Arrangement: For a campus type of facility where multiple buildings are served by the central chilled water plant, or where all cooling load is not scheduled to be activated at the same time, tertiary piping/pumping arrangement shall be provided, as shown in [Secondary Distribution Interface Flow Diagram 2.12.5](#). Tertiary systems shall also be considered where the secondary pumping head could become excessive without tertiary pumps or where the chilled water temperature entering the system need to be higher than the chilled water temperature leaving the chiller(s).

(5) Chilled Water Temperature Differential: The chilled water temperature differential across the chiller be optimized but shall not be less than -12 degrees C (10 degrees F) Consider the impact of piping, pumping cost, cooling coil performance, and chilled water piping arrangement in order to optimize the chilled water differential.

(6) Chilled Water Filter: A cartridge type of water filters shall be provided across pumps per VA Standard Detail 15705.16. The filter capacity shall not be more than 1 percent of the total flow in circulation.

(7) Cooling Tower Water Treatment: Water treatment for the cooling towers shall be provided and the equipment location shall be shown on the drawings. The equipment location shall make an allowance for the chemical drums (in use and spares) and their movement in and out of the chilled water plant. If the chemicals feed pump is interlocked with the cooling tower flow, the treatment

chemicals may be put into the condenser return piping. If a cooling tower bypass is included in the system design, the bypass should discharge into the cooling tower basin(s) rather than into the cooling tower outlet piping.

2.12.3 CENTRAL CHILLED WATER PLANT FLOW DIAGRAM

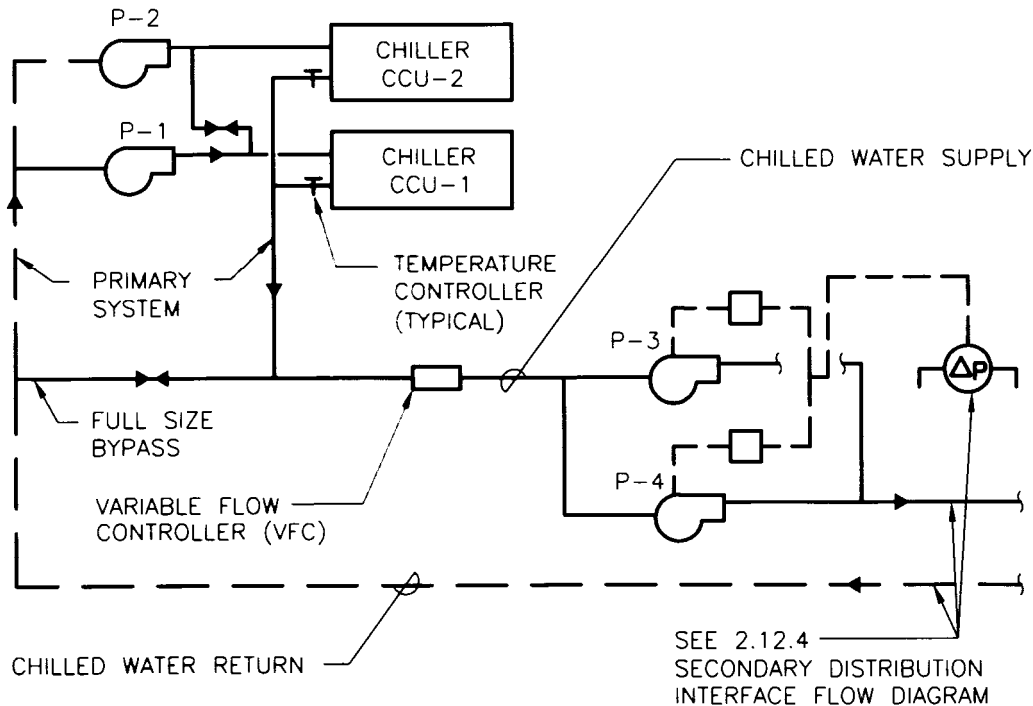

VARIABLE FLOW DISTRIBUTION WITH CONSTANT FLOW CHILLERS

NO SCALE

Notes:

(a) The above arrangement shall be used for chilled water systems that require two chillers to meet the cooling load. The chillers shall be air or water-cooled.

(b) Primary chilled water pumps P-1 and P-2 shall be sized for the pressure drop (PD) of the chiller and related piping.

(c) Secondary chilled water pumps P-3 and P-4, 50 percent capacity each, shall be of variable flow type.

(d) Variable flow controller (VFC) shall be used for 7.5 HP and larger pumps. It shall measure the flow and provide a signal to start/stop primary pumps according to predetermined flow set-point ranges.

(e) Differential pressure control (ΔP) shall vary the speed of Pumps P-3 and P-4.

(f) Other pumping systems may be considered but must be submitted to VA for approval.

2.12.4 SECONDARY DISTRIBUTION INTERFACE FLOW DIAGRAM

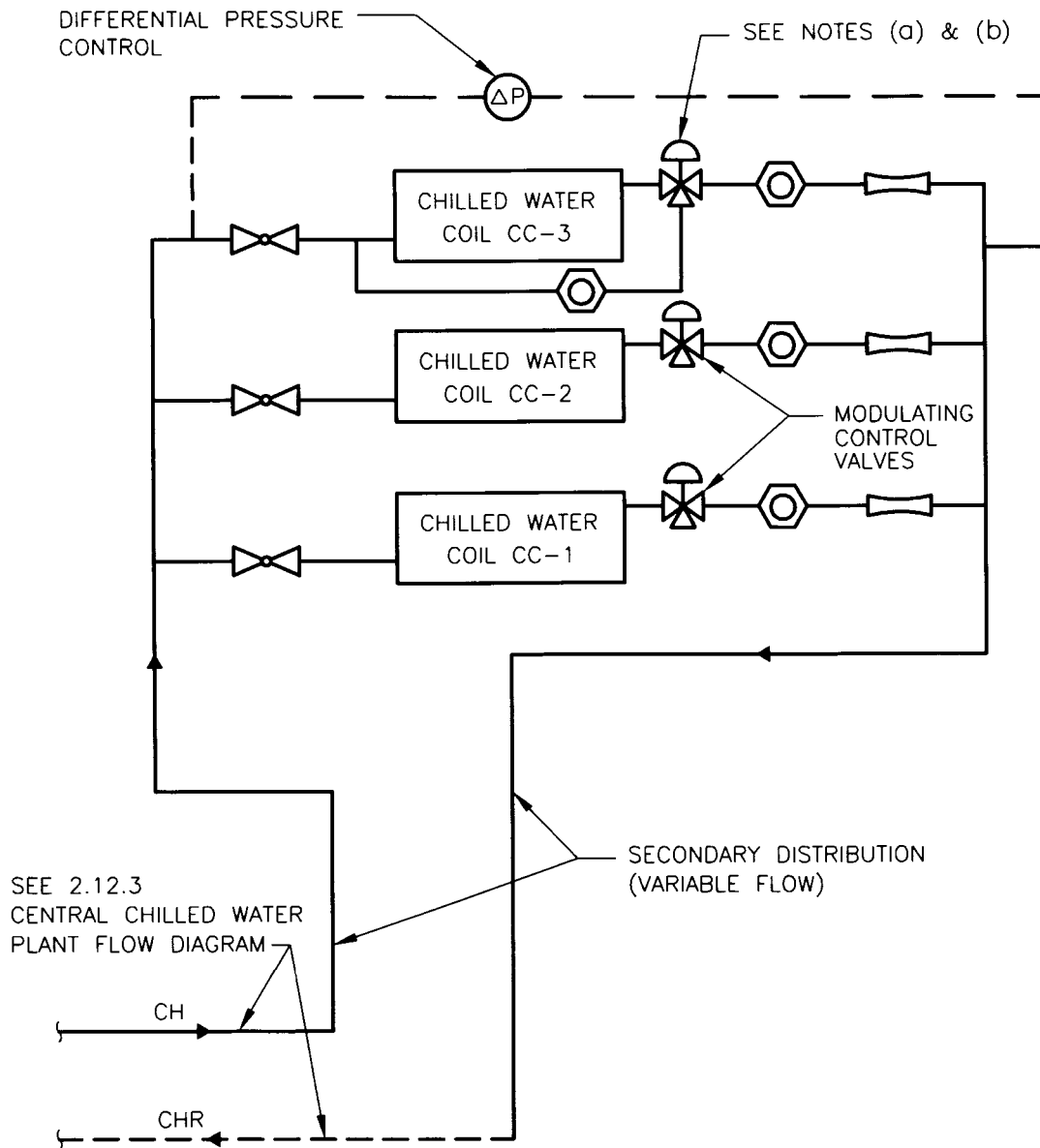

SECONDARY DISTRIBUTION

NO SCALE

Notes:

(a) Maintain at least 15 percent flow through pump(s) by the use of a 3-way control valve.

(b) Alternately provide a 2-way control valve for CC-3 and a 2-way automatic bypass valve at CC-3 to provide for an automatic bypass of chilled water when the coil control valve begins to close. The automatic bypass valve and line shall be sized to handle 15 percent (minimum) pump flow.

2.12.5 SECONDARY/TERTIARY DISTRIBUTION INTERFACE FLOW DIAGRAM

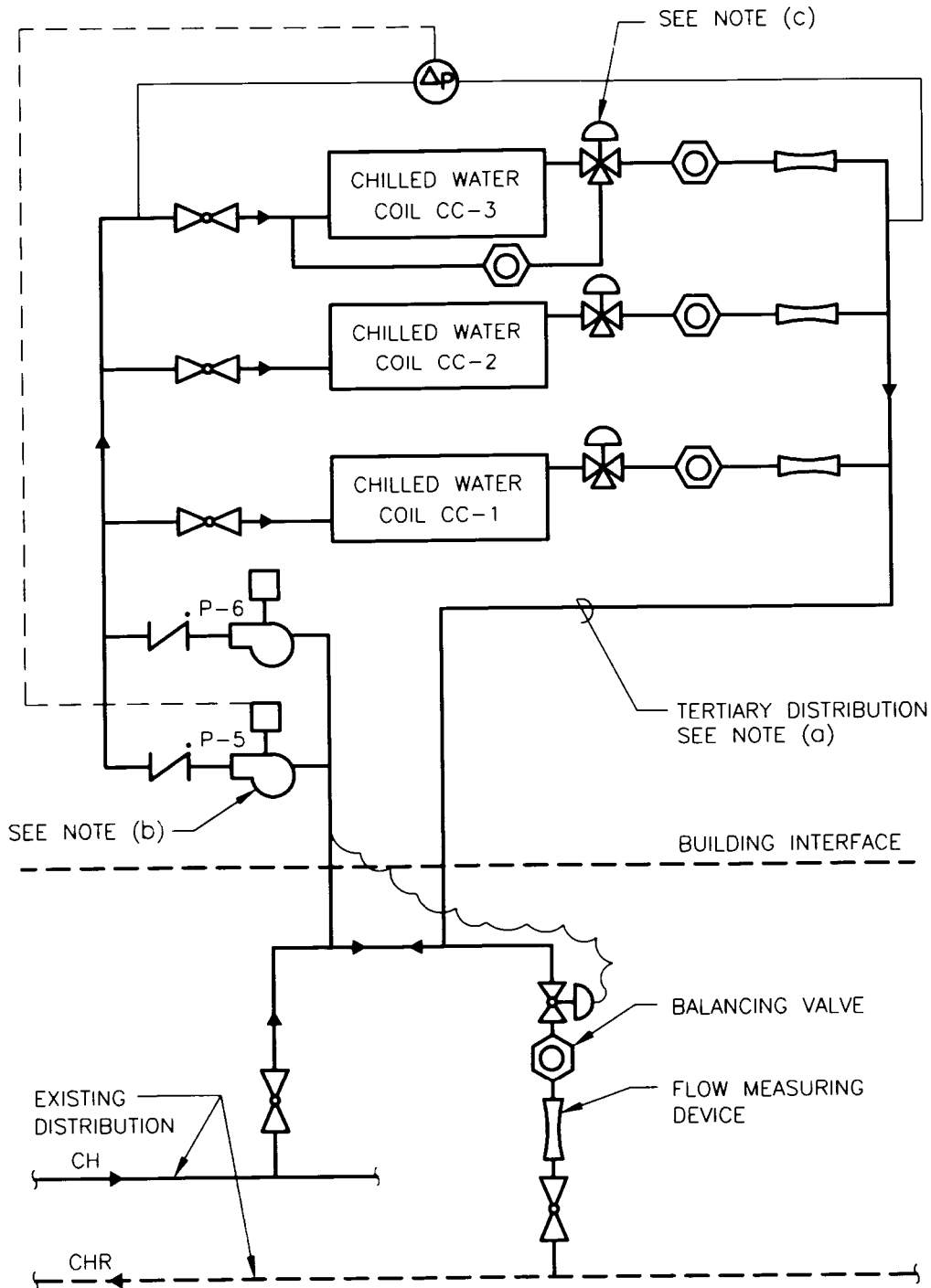

SECONDARY/TERTIARY DISTRIBUTION INTERFACE

NO SCALE

Notes:

(a) For application of tertiary distribution arrangement, see [paragraph 2.12.2](#), Central Chilled Water Systems.

(b) Secondary pumps, P5 and P6, each rated at 50 percent of design flow and design head, with motors sized for single pump operation. 7.5 HP and larger pumps shall be of variable speed type.

(c) Maintain 15 percent (minimum) pump flow by use of 3-way coil valve(s). Alternately, provide a 2-way control valve for CC-3 and a 2 way automatic bypass valve at CC-3 to provide for an automatic bypass of chilled water when the coil control valve begins to close. The automatic bypass valve and line shall be sized to handle 15 percent (minimum) pump flow.

2.12.6 DX REFRIGERATION SYSTEMS

2.12.6.1 APPLICATION: The use of DX refrigeration system is not permitted for patient care and waiting areas. Use chilled water from a stand-alone chiller or a central chilled water plant, if available. DX systems are allowed in non-patient areas such as administrative areas in localities not considered as high humidity areas. Areas of the country, having above mean annual dew point temperature of 40-45 degrees are considered high humidity areas.

The DX system should be carefully evaluated under the following situations:

(a) The facility does not have a central chilled water plant with any spare capacity.

(b) The central chilled water plant shuts down in winter. But a few specific areas require mechanical cooling.

(c) Connections to the existing chilled water plant could involve extensive chilled water piping and pumping costs, thereby making use of the existing chilled water plant impractical.

(d) Whenever the project involves special applications requiring back-up cooling, for the following areas:

(1) Telephone Equipment Rooms

(2) Elevator Machine Rooms

(3) Central Warehouses. See [Article 1.3](#) for the specific areas within the central warehouse requiring mechanical cooling.

(e) Can be considered for other areas, when appropriate humidity controls are made.

2.12.6.2 EQUIPMENT SELECTION: If the capacity range permits, the chiller selection shall be based on the multiple compressors and refrigeration circuits to ensure energy conservation and operation flexibility.

2.12.6.3 REFRIGERANT PIPING: Wherever the system configuration involves field installed piping, the same shall be sized and designed in accordance with the manufacturer's recommendations. The complete piping layout, including all accessories, such as double suction risers, solenoid valves, expansion

valves, oil separators, refrigerant receivers, etc., shall be shown clearly on the floor plans and schematic layout drawings.

2.12.7 REFRIGERATION SYSTEMS FOR SURGERY SUITES

2.12.7.1 AREAS SERVED: Separate refrigeration system(s) shall be provided to serve surgery suite, intensive care units, and recovery rooms.

2.12.7.2 SYSTEM TYPE: To facilitate easy start in mild weather, the dedicated chiller(s) serving the surgery suite and the associated areas shall be air cooled water chiller with dedicated chilled water distribution piping and pumps. The chilled water system for surgery area shall be cross connected to the central chilled water plant, if existing.

2.12.7.3 SYSTEM CAPACITY/OPERATION:

(a) Capacity: The chiller(s) capacity shall match the cooling load required for the surgery suite and the associated areas. Two chillers of equal capacity with chilled water at about 5 degrees C (42 degrees F) shall be provided. However, with a central chilled water plant, in service, a single chiller with multiple compressors can be used.

(b) Operation: The air-cooled chillers shall be the prime source of cooling for the surgery suite because it requires lower space temperatures. The surgery chiller and the air handling unit operate at temperatures, typically 5 degrees C (42 degrees F) or below compared to normally 6.5-7.0 degrees C (44-45 degrees F) temperatures associated with a central chilled water plant.

2.12.8 REFRIGERATION SYSTEMS FOR ANIMAL RESEARCH AREAS

2.12.8.1 AREAS SERVED: Separate refrigeration system(s) shall be provided to serve animal research areas including holding areas, surgical facilities, laboratories, and associated support areas.

2.12.8.2 SYSTEM TYPE: Same as [2.12.7.2](#) above.

2.12.8.3 SYSTEM CAPACITY/OPERATION: Same as [2.12.7.3](#) above.

2.12.9 REFRIGERATION SYSTEMS FOR SPECIALTY AREAS

2.12.9.1 GENERAL: Dedicated refrigeration systems are required for the following areas. See Chapter 3 for specific details. The refrigeration systems can be DX or chilled water type, preferably air-cooled and shall be cross-connected to the central chilled water plant, if feasible.

2.12.9.1.1 LINEAR ACCELERATORS: See [Article 3.15](#).

2.12.9.1.2 MRI (Magnetic Resonance Imaging) UNITS AND CT SCANNERS: See [Article 3.17](#).

2.12.9.1.3 TELEPHONE EQUIPMENT ROOMS: See [Article 4.8](#).

2.12.9.1.4 ELEVATOR MACHINE ROOMS: See [Article 2.10.5](#).

2.12.9.1.5 MEDICAL MEDIA SERVICE (MMS): See [Article 3.16](#).

2.12.10 FREEZE PROTECTION - Chilled Water System

Adequate protection shall be provided for chilled water to avoid potential problems associated with freeze up.

2.12.10.1 CHILLED WATER: The following measures shall be evaluated to protect the coils and pipes carrying chilled water. Select one or more options, as deemed necessary.

(a) Heat Tracing: All exposed chilled water piping shall be heat traced with thermostatically controlled electric tape. See VA Master Specification Section 15705, HVAC PIPING SYSTEMS and [Article 2.16](#) for emergency power requirements.

(b) Remote Air Cooled Condenser: Entire chilled water piping shall be kept indoor by locating only the air-cooled condenser outdoors.

(c) Partial Draining: Only the exposed chilled water piping shall be drained. The indoor chilled water piping shall remain filled with water. This measure will require drain valves and isolating valves at appropriate locations in the chilled water piping.

(d) Automatic Flow Activation: The chilled water flow shall be activated automatically when the chiller is idle, below preset ambient temperature and/or chilled water temperature in exposed piping to prevent freeze up.

(e) Use of the glycol water solution shall be limited due to the following reasons:

(1) Loss of heat transfer efficiency, approximately 5-10 percent, in the chiller and cooling coil operation.

(2) Higher pumping cost due to higher pump head.

(3) Higher initial cost, associated with glycol, fill station, piping, pump, etc.

(4) Higher maintenance costs associated with additional equipment and higher operating parameters.

2.12.11 FREEZE PROTECTION-Condenser Water System

The cooling towers shall be winterized as follows:

(a) Provide thermostatically controlled basin heaters if the cooling tower is scheduled to remain in operation during fall and winter. All exposed condenser water piping shall be heat traced.

(b) Partial Draining: Only exposed condenser water shall be drained during fall and winter when the cooling tower is not in operation. With this measure, it will be possible to partially save the water chemicals. A set of drain and isolation valves will be required to facilitate draining.

2.12.12 PRE-INSULATED CHILLED WATER PIPING

2.12.12.1 UNDERGROUND CHILLED WATER PIPING: The basic requirements shall be in accordance with the VA Master Specification, Section 15706, HVAC PIPING SYSTEMS. The principle features are:

- (a) All chilled water supply piping shall be insulated.
- (b) Chilled water return piping 300 mm (12-inch) diameter and smaller shall be insulated.
- (c) Chilled water return piping 350 mm (14-inch) diameter and larger shall not be insulated.
- (d) Piping under buildings and roads shall be steel.

2.12.12.2 SPECIAL REQUIREMENTS FOR HIGH HUMIDITY AREAS: Insulation for chilled water piping and cold vessels shall be cellular glass type. See VA Master Specification, Section 15250.

2.12.13 DOCUMENTATION REQUIREMENTS

2.12.13.1 SCHEMATIC DIAGRAM: A schematic control diagram of the entire chilled water system shall be shown on one drawing so that there is a comprehensive understanding of the system configuration and the intended mode of operation. Partial and incomplete diagrams shall be unacceptable. The diagram shall be complete with, but not limited to, the following:

- (a) Temperature sensors
- (b) Control valves
- (c) Pressure Differential Assemblies
- (d) Expansion tanks
- (e) Air separators
- (f) All valves and piping specialties not shown on standard details
- (g) Water Filters
- (h) Chemical Feeders
- (i) Water treatment for cooling towers
- (j) Measures taken to prevent dead heading of pumps
- (k) Water make-up connections
- (l) Drain Connections
- (m) Variable speed drives, if required
- (n) Flow control and measuring devices

2.12.13.2 EQUIPMENT ROOMS

(a) Space Planning: Ample space shall be provided to service and repair the refrigeration equipment. The tube pull space shall be clearly shown on the drawings. Overhead hoist beams shall be provided, as required, to facilitate the removal of the condenser and evaporator heads. Piping shall have the

necessary offsets and mechanical couplings or flanges to permit removal of heads and tubes.

(b) The floor plans and at least two cross sections shall be drawn at 1:50 (1/4") scale to show clearances and access spaces. The designer shall not rely on the construction shop drawings to be assured of the adequate maintenance space.

2.12.13.3 CALCULATIONS: Pump head calculations shall be based on the actual piping layout and takeoffs. Add an additional 10 percent safety factor to the total calculated pump head.

2.12.13.4 PIPING SUPPORTS: For the condenser and chilled water pipe sizes 10 inches and larger, the pipe support shall be engineered and all supports/hanger sizes and locations shall be shown on drawings. In addition, the interface of the upper attachment of the pipe hangers shall be coordinated with the structural drawings; auxiliary steel, as required to support the pipe hangers from the building structure, shall be shown on the drawings. The designer shall submit complete engineering calculations to the VA to ensure compliance with this requirement.

2.12.13.5 VARIABLE SPEED DRIVES

(a) Variable/Constant Flow Pumps: With variable flow chilled water systems, variable speed drive pumps shall be used for the secondary and tertiary chilled water distribution systems. The designer shall ensure that all distribution pumps are equipped with the variable speed drive packages rather than only one or two pumps within the distribution system. This design feature is essential to ensure that all secondary pumps, while operating in parallel, run at the same speed and double up the same pumping head. Otherwise, with one constant speed pump and another variable speed pump, both connected in parallel, a situation could develop where the check valve of the variable speed pump may not be able to open, particularly at lower operating speeds.

(b) Existing Systems: The use of the variable speed drives shall be carefully evaluated for the existing chilled systems, where three-way automatic control valves are furnished for the cooling coils. For such retrofit applications, the existing 3-way valves must also be changed to 2-way automatic control valves and pressure differential assembly along with variable speed drive for pumps.

2.13 SMOKE AND FIRE PROTECTION

2.13.1 GENERAL

2.13.1.1 The HVAC systems for the VA facilities shall be designed to meet the requirements of the National Fire Protection Association codes, NFPA 45, 72E, 90A, 96, 99, and 101, and the additional provisions outlined in this section. The local building codes, with the provisions in excess of these requirements, are not legally binding on the VA. The A/E shall, nevertheless, familiarize himself with these requirements, discuss their stringency and applicability with the VA, and resolve the need to implement them in the system design.

2.13.1.2 The subdivision of the building spaces into smoke zones shall conform to NFPA 101. All smoke partitions shall be shown on the HVAC floor plans exactly as depicted on the architectural floor plans.

2.13.1.3 All duct-mounted smoke detectors, furnished by the electrical discipline, shall be shown on the HVAC drawings. The duct-mounted smoke detectors, if and when furnished in conjunction with the duct mounted smoke dampers, shall always be installed on the upstream side of the dampers. (Refer to VA Standard Detail 15900-20). The space-mounted smoke detectors need not be shown on "H" drawings.

2.13.1.4 The sequence of operation for the duct (or space) mounted smoke detectors, shall be described with the automatic temperature control drawings of the affected HVAC systems.

2.13.1.5 All duct-mounted smoke and combination fire/smoke dampers shall be individually numbered, shown and scheduled on "H" drawings in accordance with the VA Standard Detail 15000-48.

2.13.2 SMOKE CONTROL

2.13.2.1 GENERAL: Smoke control systems for all HVAC systems, except atriums, shall be automatic shutdown type as described in the next paragraphs. The use of the engineered smoke control systems is not permitted.

2.13.2.2 SMOKE DETECTORS - SUPPLY AIR SYSTEMS: For all supply air systems, with capacities in excess of 56 cu m/Min (2,000 CFM), a duct mounted smoke detector shall be shown in the main supply air duct on the downstream side of the after-filters and prior to any takeoffs. When activated, this detector, through its auxiliary contacts, shall do the following. It should be, however, noted that duct-mounted smoke detector is not required in the main return air duct to correspond with a duct detector installed in the supply air duct. The smoke dampers are required only if the air handling unit serves multiple floors.

- (a) Stop the supply air fan
- (b) Stop the return air fan associated with supply air fan
- (c) Send an alarm signal to the building fire alarm system
- (d) Send an alarm signal and printed message to Engineering Control Center (ECC)

2.13.2.3 SMOKE DETECTORS/DAMPERS - SUPPLY AIR SYSTEMS WITH RETURN AIR FANS: In addition to what is stated in [paragraph 2.13.2.2](#) above for air handling units, Supply Air Systems larger than 420 Cu M/Min (15,000 CFM) and serving more than one story shall have the following provisions:

(a) Provide duct-mounted smoke detectors in each branch return air duct, at each floor, as the branch duct enters the main vertical return air duct.

(b) Isolate air-handling units by providing smoke dampers in the supply and return air ducts as shown in Smoke and Fire Protection Control [Diagram 2.13.4](#).

(c) Upon activation of any duct-mounted smoke detector in addition to the actions outlined above [paragraph 2.13.2.2](#), the smoke dampers installed at the air-handling unit shall close.

2.13.2.4 SMOKE DETECTORS/DAMPERS - SUPPLY AIR SYSTEM WITH EXHAUST AIR FAN (NO RETURN AIR):

2.13.2.4.1 In addition to what is stated in [paragraph 2.13.2.3](#) above, for the supply air systems larger than 420 Cu M/Min (15,000 CFM) capacity and using 100 percent outdoor air, the air handling units shall be isolated by providing smoke dampers in the supply air ducts as shown in Smoke and Fire Protection Control [Diagram 2.13.4](#). This damper shall be closed when the duct-mounted smoke detector, installed in the main supply air duct, is energized. The smoke damper is required only if the unit serves more than one story.

2.13.2.4.2 Both the NFPA Codes and the VA Design Criteria do not require either a duct-mounted smoke detector or a smoke damper in the main exhaust air duct to be connected to the exhaust air fan.

2.13.2.5 SMOKE BARRIER

2.13.2.5.1 For a fully sprinklered building with quick response sprinklers, duct mounted smoke detectors or smoke dampers are not required in supply, return, and exhaust air ducts crossing the smoke barriers. This is a trade off permitted by the Life Safety Code NFPA 101.

2.13.2.5.2 If the building is not fully sprinklered or sprinklered with normal response sprinklers, for each duct penetration of the smoke barrier, a dedicated duct mounted smoke detector and an accompanying smoke damper are required. The sequence of operation shall be such that, when activated, the duct-mounted smoke detectors, through its auxiliary contacts, shall:

- (a) Close the associated smoke dampers.
- (b) Send an alarm signal to the building fire alarm system.
- (c) Send an alarm signal and a printed message to Engineering Control Center (ECC).
- (d) The corresponding supply, return, and exhaust air fans shall continue to run. The fans may be sequenced to shutdown if any excessive build-up of the air static pressure could result due to volumetric imbalance. The system designer/reviewer shall, therefore, evaluate the air balance for each system involving damper closure and make a determination on a case-by-case basis about the need to stop the fans.
- (e) Space-mounted smoke detector installed at the corridor above smoke door shall close all smoke dampers installed in ducts passing above the corridor smoke door.

2.13.2.6 ATRIUMS: The smoke control system for atriums shall be designed in accordance with the following:

2.13.2.6.1 Provide an engineered smoke control system primarily designed to remove the smoke from the atrium so that it does not contaminate the

adjoining areas. The system capacity shall be based on the NFPA 92B and Uniform Building Code (UBC-1994 edition) Sections 402 and 905 requirements.

2.13.2.6.2 The engineering calculations showing derivation of the exhaust system capacity shall be performed by the fire protection engineer.

2.13.2.6.3 The smoke removal system should be activated manually as well as automatically. In the automatic mode, either a sprinkler flow switch, or a grid of the beam type of smoke detectors should energize the smoke removal system. The sprinklers are usually installed at 17 m (55 feet) or below.

2.13.2.6.4 The make-up air system for the smoke removal, if required, will vary with the layout of the atrium and the surrounding spaces. Normally, upon activation of the smoke removal system, the dedicated air-handling unit serving the atrium, for its normal cooling and heating requirements, should be designed to go to 100 percent outdoor air mode. The additional make-up air, to comply with the code, should be brought in by a dedicated make-up air unit. This unit should operate during the smoke removal mode only. Depending upon the severity of weather, 4 degrees C (40 degrees F) or below, the make-up air should be heated to 12 degrees C (55 degrees F) temperature. For milder climate, the make-up air can be admitted to the atrium directly from outdoor, with or without ductwork, depending upon the physical configuration of the atrium and the surrounding spaces. The use of the building air from the other air-handling units serving the occupied spaces shall be avoided to prevent any possibility of contamination.

2.13.2.6.5 HVAC equipment used in smoke control system shall conform to NFPA 92B, 1995 edition and UBC, 1994 edition requirements.

2.13.2.7 STAIRWELLS: Pressurization of stairwells is not required.

2.13.2.8 ELEVATOR SHAFT VENTING

2.13.2.8.1 Rule 100.4 of ANSI.1, Elevator Safety Code requires venting of all elevator hoistways. Provide normally closed, two-position motorized dampers in hoistway vents. See VA Standard Detail 15900-18. Vent dampers shall open when smoke is detected by the space detector located at the top of each elevator hoistway.

2.13.2.8.2 There are two automatic methods by which hoistway vent dampers shall operate. Select one of the methods depending upon the following:

(a) The first method is via a system of smoke detector when sprinklers are provided at the top of the hoistway.

(b) The second and more common method is via a 120V single station smoke alarm triggered by the smoke detector that is not connected to the building fire alarm system. This method shall be applied when sprinklers are not required at the top of the elevator hoistway (non-combustible shaft construction and elevator cabs meet flame spread requirements per ASME A17.1). The VA Fire Protection Design Manual does not require this smoke alarm. However, VA Elevator Criteria requires this due to its preference.

(c) Regardless of the method selected, the position of the elevator hoistway vent damper shall be monitored at the ECC.

2.13.2.9 MISCELLANEOUS REQUIREMENTS

2.13.2.9.1 Smoke dampers are not required in the interstitial deck penetrations.

2.13.2.9.2 Smoke detectors shall be located on the upstream side of the duct-mounted humidifiers. Where the smoke detectors have to be located on the downstream side of the humidifiers, maximum possible distance shall be maintained between them.

2.13.2.9.3 Wherever possible, the smoke detectors shall be preceded by a straight duct run for at least six duct widths to ensure fairly uniform airflow and homogenous air/smoke mixing.

2.13.3 PENETRATIONS OF FIRE AND SMOKE BARRIERS

Penetrations of fire walls, fire partitions, shafts, ceilings, and floors shall be protected as required by NFPA 90A, and NFPA 101 with the following amplifications:

2.13.3.1 Fire dampers are required in the duct penetrations of the fire walls and fire partitions with a fire resistance rating of 2 hours or greater.

2.13.3.2 Fire dampers are not required in duct penetrations of the corridor walls rated less than 2 hours. Note that in a fully sprinklered building, the corridor walls are not fire rated except when used as means of egress. Transfer grilles shall not be installed in the corridor walls of the health care facilities even if they are equipped with fusible link fire dampers, with the exception of toilets, bathrooms, and janitor closets (HAC), which open to the corridor.

2.13.3.3 FIRE DAMPERS IN LABORATORY FUME HOOD EXHAUST SYSTEMS: NFPA 45, does not permit fire dampers in laboratory fume hood exhaust systems. The exhaust from laboratory fume hoods shall be limited to a single fire zone. Provide a separate fire rated shaft from each fire zone for laboratory fume hood exhaust to reach the top of the building. When the quantity of laboratory hoods prohibits a separate shaft from each fire zone, one shaft may be used for the laboratory hood exhaust ducts without fire dampers based on NFPA 90A.

2.13.3.4 PENTHOUSE FLOOR DUCT PENETRATIONS: Provide fire dampers only if the penthouse is, or will in the future be, considered a story of the building. A story is defined as either exceeding 90 Sq M (1000 Sq Ft) or one-third of the roof area.

2.13.3.5 For the wood-framed attics used for mechanical rooms in the existing buildings, fire dampers are not required in floor penetrations. The metal duct provides the required 1-hour separation.

2.13.3.6 VA HOSPITAL BUILDING SYSTEMS: Fire dampers are only required where the interstitial deck penetrations are located over an exit passageway (corridor serving as a two hour passageway no space) and/or where the interstitial deck penetration openings exceed 0.1450 Sq M (225 Sq Inches). This means a duct of 325 mm x 325 mm (13-inch x 13-inch). Seal openings per VA Standard Detail 15840-14.

2.13.3.7 OTHER LOCATIONS NOT REQUIRING FIRE DAMPERS:

(a) Outdoor air intake where there is no combustible material within 30 mm (100 feet). (Roofing is not considered combustible). Provide intakes with corrosion resistant screens. Screen mesh shall be no larger than one-half inch mesh (NFPA 90A).

(b) Exhaust ducts through exterior walls.

(c) Duct penetrations of roof.

(d) Duct penetrations of one-hour partitions, except in a one-hour vertical shaft enclosure, according to NFPA-90A.

2.13.4 SMOKE AND FIRE PROTECTION

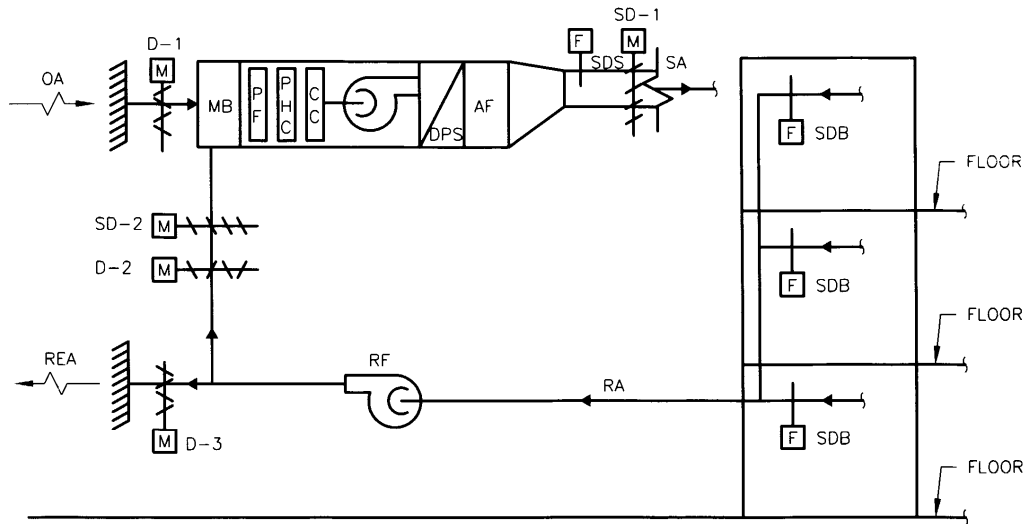

SMOKE CONTROL FOR AIR HANDLING UNIT SYSTEMS

NO SCALE

LEGEND

D-1	OUTDOOR AIR DAMPER	AF	AFTER FILTER SECTION
D-2	RETURN AIR DAMPER	CC	COOLING COIL SECTION
D-3	RELIEF AIR DAMPER	DPS	DIFFUSION PLATE SECTION
SD-1	SA DUCT SMOKE DAMPER, see Note (a)	MB	MIXING BOX
SD-2	RA DUCT SMOKE DAMPER. See Note (a)	OA	OUTSIDE AIR
F SDS	SA DUCT DETECTOR. See Note (b)	PF	PREFILTER SECTION
F SDB	BRANCH SA DUCT DETECTOR. See Note (c)	PHC	PREHEAT COIL SECTION
SA	SUPPLY AIR	RA	RETURN AIR
SF	SUPPLY FAN	REA	RELIEF AIR
RF	RETURN FAN		

Notes:

(a) These dampers are required for air handling units larger than 420 Cu M/Min (15,000 CFM) capacities and serving more than one floor.

(b) These duct detectors are required for all air-handling units larger than 56 Cu M/Min (2,000 CFM) capacities.

(c) These duct detectors are required for all air-handling units larger than 420 Cu/Min (15,000 CFM) capacities and serving more than one floor.

2.14 AUTOMATIC TEMPERATURE CONTROL SYSTEMS

2.14.1 GENERAL

2.14.1.1 Except for small HVAC systems or factory-packaged systems, the automatic control systems shall be Direct Digital Controls (DDC) type with pneumatic, electric or electronic operators. Where the medical center prefers a 100 percent DDC Control System alternate cost estimate shall be prepared and discussed with the VA. Final selection of the type of controls shall be confirmed with the VA before proceeding with complete design of automatic temperature control system.

2.14.1.2 The flow and control diagrams for air, water, glycol, and steam systems and the sequence of operation for all HVAC systems and sub-systems shall be shown on the drawings. The diagrams shall show complete operating description including starting, interlocks, part load operation, smoke control features, volumetric controls, alarms, and emergency or power failure associated with operation of HVAC systems.

2.14.1.3 Temperature and humidity controls may be electric (small jobs only), electronic, or pneumatic, except that pneumatic or electronic control shall be required for the operating suites. Each humidistat for an operating room shall directly control a terminal humidifier through high limit controller. See [Article 2.3](#) for HVAC Equipment Requirements, and for psychiatric areas, see [Article 3.18](#).

2.14.1.4 Air compressors for pneumatic control systems shall be arranged to operate automatically with emergency generator power in the event of utility power failure. Sizing of the air compressor is the responsibility of the control system manufacturer based on a 1/3 on 2/3 off run time basis as outlined in the specification. However, the electrical service and location of the compressor must be shown on drawings.

2.14.1.5 Outdoor air temperature and humidity sensors shall be located outdoors, and not in outdoor air ducts. Provide shading for sensors. Sensors shall be protected from direct sunlight and be easily accessible.

2.14.1.6 Show local temperature control panels (LTCP) and distributed control panels (DCP) on drawings.

2.14.1.7 Control wiring and tubing shall be concealed. Use of wire mold will not be acceptable.

2.14.1.8 Mount room thermostats at 1.5 m (5 feet) above the finished floor.

2.14.1.9 ROOM TEMPERATURE CONTROL: All perimeter rooms and patient bedrooms shall have individual temperature control. As many as four small interior rooms of similar function and load may be grouped into one zone. Laboratories or other spaces, in which the supply air volume is based on special air requirements, shall also have individual temperature control.

2.14.2 ENGINEERING CONTROL CENTER (ECC)

2.14.2.1 Provide a complete Direct Digital Control (DDC) system with complete workstation consisting of a computer, monitor, keyboard, and printer for new medical centers and for the existing facilities without ECC.

2.14.2.2 The ECC of different makes are usually not compatible with each other. The following two options shall be evaluated prior to the final design of ECC, while designing a control system for a project, such as an addition and/or modifications to the medical center with an existing ECC.

(a) Expand the existing system, and consequently, provide a sole source, proprietary system for the proposed project if it is in the best interest of the VA. However, the contracting officer's approval will be required prior to implementing this option into the design.

(b) If the above option is not practical, replace the existing ECC system with a new ECC system suitable for the existing and the proposed HVAC control systems.

2.14.2.3 The "MH" drawings must include ECC and DDC schedules of input and output points for all HVAC systems and equipment as well as equipment of other trades requiring remote control and monitoring. Also, show a suitable location in each mechanical room for a Distributed Control Panel (DCP). Provide emergency power for the ECC and each DCP.

2.14.2.4 Hand-off-automatic switch, furnished by electrical, shall be provided for all motor starters on systems controlled from the ECC and DCP(s). Where applicable, the electrical designer must specify the input from utility company meters for electrical demand limiting programs and for monitoring the commercial power supply. When the optimized start/stop program is used, designer must furnish necessary load inputs to the ECC.

2.14.2.5 Uninterruptible Power System (UPS): A continuous on-line UPS shall be provided for ECC while commercial power is being switched over to emergency power.

2.14.2.6 At medical centers where an ECC operator will not be in attendance at all times, a remote alarm printer shall be located at the Boiler Plant or other location recommended by the engineering officer at the medical center.

2.14.2.7 The following points shall be monitored and controlled if the associated equipment is provided:

(a) Remote start/stop control, status indication with alarm and total run time for:

(1) Air handling unit supply and return fans

(2) Exhaust fans. Minor fans may be omitted

- (3) Pumps for chilled water, condenser water, hot water and glycol energy recovery loop
- (b) Remote reset control for:
 - (1) Supply air temperatures
 - (2) Chilled water, hot water, and condenser water temperatures
- (c) Air Handling Unit temperatures (Db):
 - (1) Return air
 - (2) Mixed air entering air-handling unit
 - (3) Air leaving preheat coil
 - (4) Air leaving air-handling unit
 - (5) Air leaving heat recovery coil
 - (6) Supply air leaving air-to-air heat exchanger
- (d) Status alarms for:
 - (1) Filters
 - (2) Freezestats and duct-mounted smoke detectors
 - (3) Vibration switch for cooling tower fan
 - (4) High temperature for lab and dietetic refrigerators/ freezers
 - (5) Low main control air pressure
 - (6) Mortuary and blood bank refrigerator/freezers
 - (7) High discharge air static pressure
 - (8) High/Low condenser water pH
 - (9) Water chiller cutout alarms
 - (10) Medical gases, vacuum systems, compressed air and emergency generators, domestic hot water systems, pneumatic tube systems, constant temperature rooms, dietetic, elevators and other remote mechanical and electrical systems such as building lighting level and on/off conveyor control, sewage pumps, etc., as applicable
 - (11) High and low temperature for each animal room and/or cubicles
- (e) Space temperature and humidity indication with alarm:
 - (1) Each operating room

(f) Space temperature indication:

- (1) Recovery room
- (2) Each intensive care unit
- (3) Cardiac procedures room

(g) Pressure indication with high/low alarm:

- (1) High pressure steam service

(h) Chilled water plant:

- (1) Chilled water supply and return temperatures and flow rates
- (2) Condenser water supply and return temperatures and flow rates

(i) Heat Exchangers:

- (1) Heating water supply temperatures and flow rate
- (2) Glycol/water system, supply and return

2.14.2.8 The following programs shall be provided as applicable:

(a) Time initiated programs

(b) Optimum start/stop

(c) Enthalpy optimization/economizers

(d) Duty cycling (Do not specify for VAV systems)

(e) Chilled water plant optimization

(f) Automatic restart of equipment sequence after power outage and upon resumption of commercial power service, and upon application of emergency power

(g) Power demand limiting

(h) Preventative maintenance instruction

(i) Fire emergency

(j) Calculating of air flows, water flows, tonnage, BTUs, W, kW, Kg/s, Cu M/Min, L/Min, (BTU, Tons, Lb./Hr., CFM, GPM), etc.

(k) Optimization control of hot deck and cold deck temperatures; air quantity control in VAV systems

(l) Optimization of lighting use

(m) Computer Diagnostic and Testing Programs: To test all programs and report malfunctions down to specific items or circuits

2.14.3 STEAM RECORDING FLOW METERS

Provide steam recording flow meters for steam turbines and steam absorption machines to record the steam flow rate in pounds per hour and total steam flow for at least a 24-hour period.

2.14.4 CONTROL ROOM

The control room shall be air-conditioned with noise level of not more than 50 decibels.

2.15 SEISMIC REQUIREMENTS (HVAC)

2.15.1 GENERAL

2.15.1.1 Earthquake-resistive design shall comply with the requirements of Construction Standards CD-54, Natural Disaster Resistive Design (Non-Structural), latest edition of VA Handbook H-18-8, Seismic Design Requirements, and the Uniform Building Code (UBC) published by International Conference of Building Officials (ICBO).

2.15.1.2 Earthquake-resistive design for HVAC equipment shall be provided where Seismic Zone Factor, "Z" value is 0.10 or greater, and for piping and ductwork where "Z" value is 0.20 or greater. The "Z" values for VA sites are listed in VA Handbook H-18-8. These values must be verified with VA for a specific project before proceeding with the design.

2.15.1.3 HVAC equipment, ductwork and piping shall be braced in accordance with the most current edition of Seismic Restraint Manual Guidelines for Mechanical Systems (SMACNA) and National Uniform Seismic Installation Guidelines (NUSIG).

2.15.1.4 Unless otherwise shown by SMACNA or NUSIG, provide required details and structural calculations to completely address seismic bracing requirements. See [paragraph 2.15.4 "CALCULATIONS"](#).

2.15.1.5 SMACNA does not cover all conditions such as, providing bracing details for seismic restraints of equipment or details of flexible joints when crossing seismic or expansion joints, or bracing of in-line equipment, etc. Also, be careful in using SMACNA details where "Z" value is more than 0.40, as these details may not apply.

2.15.1.6 Coordinate earthquake-resistive design with the project Professional Structural Engineer for appropriateness and soundness.

2.15.1.7 Both, SMACNA and NUSIG list conditions under which seismic bracing may be omitted. However, a design professional may revoke these omissions on an individual project basis.

2.15.2 CONFORMANCE WITH SMACNA

2.15.2.1 Design professional should develop a Seismic Hazard Level (SHL) for a specific project for use of its manual. The SHL is derived from a combination of factors such as applicable building codes, seismic zones, and importance factors into a single system for determining appropriate bracing or restraints. A building with an SHL of "A" requires the strongest restraints, whereas, a building with SHL

of "C" requires the least restraints. The design professional is responsible for specifying the SHL not the building contractor.

2.15.2.2 Bracing in SHL "A" is designed to resist 48 percent of the weight of the ducts or pipes. Bracing in SHL "B" is designed to resist 30 percent, and in the bracing in SHL "C" is designed to resist 15 percent of the weight of the ducts or pipes. In addition to the horizontal seismic force, a vertical seismic force, equal to one-third of the horizontal force, is included in the analysis.

2.15.2.3 Current building codes require most structures and their components to be designed for a horizontal seismic force that is a given percent of the supported weight. Each code has its own method for determining the percent. The formulas are in the form:

$$F_p = C_s \times W_p$$

W_p is the weight of the ducts or pipes

F_p is the seismic force

C_s is a seismic coefficient, which represents a combination of factors that varies with the building code

Use more severe of the Local Code and the Uniform Building Code (UBC) to determine seismic force, F_p

2.15.2.4 The percent horizontal seismic factor is:

$$F \text{ (Percent)} = (F_p/W_p) \times 100$$
$$= C_s \times 100$$

If F (Percent) is greater than 48, then manual cannot be used, and an independent analysis and design is required for all bracing components.

2.15.2.5 Use SHL "A" if F (Percent) is between 31-48, use SHL "B" if F (percent) is between 16-30, and use SHL "C" if F (percent) is 15 or less.

2.15.3 CONFORMANCE WITH NUSIG

2.15.3.1 NUSIG has developed guidelines as a service to the design professionals. The guidelines are not intended as a substitute for design. The design of seismic bracing remains the responsibility of the design professional, who must review the specific project for its applicability before using or specifying NUSIG guidelines.

2.15.3.2 NUSIG manuals of designs are pre-calculated from 0.05g through 1.00g in increments of 0.05g. Coordinate with Construction Standard, CD-54.

2.15.4 CALCULATIONS

Unless otherwise shown by SMACNA or NUSIG, provide detailed structural calculations for VA's review on design of hangers, supports, anchor bolts, and connections. Show sizes, spacing, and length for securing to

structural members, and length and sizes of welds anchored to steel members.

2.15.5 DRAWINGS

2.15.5.1 Where SMACNA or NUSIG details are incomplete or not applicable, show complete seismic restraint requirements and coordinate with the specifications. Coordinate mechanical work with architectural and structural work. Special provisions and details may be required.

2.15.5.2 Ductwork and Piping Plans and Sections: Show locations of required restraints with reference to SMACNA, NUSIG or special restraint details, whichever is applicable.

2.15.5.3 Equipment Restraints: Provide special details where required. Pay particular attention to suspended equipment.

2.16 EMERGENCY POWER FOR HVAC

2.16.1 GENERAL

Refer to Electrical Design Manual Construction Standard 800-3 and NFPA 99, Essential Electrical Systems for Health Care Facilities.

2.16.2 LIST OF HVAC EQUIPMENT ON EMERGENCY POWER

- (a) The engineering control center (ECC), each field cabinet, the control air compressors and dryers, and any electric controls for systems on emergency power
- (b) Fan motors for laboratory fume hoods, H3, H7, H12 (B1 and B2 only), and H13 and H14
- (c) Refrigeration system and controls for food storage refrigerators and freezers
- (d) All supply and exhaust fans, water chillers, chilled water circulating pumps and controls for surgical suites, intensive care units, recovery rooms, and Coronary Care Units, and return air fans for intensive care units and recovery rooms when used
- (e) All supply and exhaust fans, water chillers and chilled water circulating pumps and controls for Animal Research Facility
- (f) Absorption chillers to prevent crystallization during a power failure
- (g) Heating equipment as required by NFPA 99 where outdoor winter design temperature is -6.5 degrees C (20 degrees F) or less. Heating of general patient rooms may not be required under certain conditions. See NFPA 99
- (h) Ventilation/cooling equipment for emergency generator rooms and elevator machine rooms
- (i) Exhaust fans for isolation rooms. See [paragraph 3.21.4.5](#) under TB criteria for possible exception for TB isolation room exhaust fan

- (j) ETO Exhausts Systems
- (k) Steam Condensate Return Pumps
- (l) Autopsy Exhaust Fans
- (m) Back up HVAC system for telephone equipment rooms
- (n) HVAC equipment for MRI suites and CT Scanners
- (o) Closed loop water chilling equipment for Linear Accelerators
- (p) Exhaust fans for Reagent Grade Water Treatment Room
- (q) Exhaust fans for Orthotic Laboratory special exhaust systems
- (r) Exhaust fans for Xenon and Radioactive Iodine ventilation systems
- (s) Computer Room A/C systems
- (t) Exhaust fans for Battery Charging Areas
- (u) Exhaust fans for Flammable Storage Rooms
- (v) Exhaust fan for Illustration Rooms (Medical Media)
- (w) HVAC Equipment for Bone Marrow Transplant (BMT) Areas
- (x) Electric tape for heat tracing of exposed chilled water piping and condenser water requiring freeze protection
- (y) HVAC equipment serving critical areas of outpatient clinics in seismic and high-risk hurricane areas
- (z) Atrium smoke control equipment
- (aa) Ventilation equipment (supply and exhaust fans) for Minor O.R. (Trauma Room)

CHAPTER 3: HVAC REQUIREMENTS FOR
OCCUPIED AREAS

- 3.1 AMBULATORY CARE - EVALUATION AND EMERGENCY AREA
 - 3.1.1 GENERAL
 - 3.1.2 MINOR O.R. (TRAUMA ROOM)
- 3.2 AMBULANCE ENTRANCES
 - 3.2.1 GENERAL
 - 3.2.2 SPECIAL DESIGN CONSIDERATIONS
- 3.3 ANIMAL RESEARCH FACILITY
 - 3.3.1 GENERAL
 - 3.3.2 SPECIFIC REQUIREMENTS
 - 3.3.3 ANIMAL OPERATING ROOMS
 - 3.3.4 CAGE WASHERS
- 3.4 AUDIOLOGY SOUND SUITES
 - 3.4.1 NOISE CRITERIA
 - 3.4.2 SPECIFIC REQUIREMENTS
- 3.5 AUDITORIUMS AND THEATERS
 - 3.5.1 GENERAL
 - 3.5.2 HVAC REQUIREMENTS
- 3.6 BONE MARROW TRANSPLANT (BMT) PATIENT AREAS
 - 3.6.1 GENERAL
 - 3.6.2 SPECIAL CONSIDERATIONS
- 3.7 CT SCANNER
 - 3.7.1 GENERAL
 - 3.7.2 INDOOR DESIGN CONDITIONS
 - 3.7.3 EMERGENCY POWER REQUIREMENTS
 - 3.7.4 CT SCANNER HVAC SYSTEMS
- 3.8 COMPUTER ROOMS
 - 3.8.1 GENERAL
 - 3.8.2 INDOOR DESIGN CONDITIONS
 - 3.8.3 CONSTRUCTION STANDARDS
 - 3.8.4 EMERGENCY POWER REQUIREMENTS
 - 3.8.5 HVAC SYSTEM DESCRIPTION
 - 3.8.6 SPECIAL CONSIDERATIONS
- 3.9 DENTAL PROSTHETICS LABORATORY
 - 3.9.1 COOLING LOAD
 - 3.9.2 CERAMIC ROOM
 - 3.9.3 LABORATORY
- 3.10 INTENSIVE CARE UNITS (ICU'S) (MEDICAL, SURGICAL AND CORONARY)
 - 3.10.1 INDOOR DESIGN CONDITIONS
 - 3.10.2 SUPPLY AIR
 - 3.10.3 PRESSURE RELATIONSHIP
 - 3.10.4 EMERGENCY POWER REQUIREMENTS
 - 3.10.5 SPECIAL REQUIREMENTS
- 3.11 ISOLATION ROOMS
- 3.12 KITCHEN AND KITCHEN FOR LARGE CAFETERIAS
 - 3.12.1 GENERAL
 - 3.12.2 INDOOR DESIGN CONDITIONS
 - 3.12.3 SUPPLY AIR

- 3.12.4 EXHAUST AIR
 - 3.12.5 AIR PRESSURE RELATIONSHIP
 - 3.12.6 NOISE CRITERIA
 - 3.12.7 EXHAUST SYSTEMS, KITCHEN HOODS
 - 3.12.8 EXHAUST SYSTEMS - WET EXHAUST
 - 3.12.9 HOT AIR DISCHARGE
 - 3.12.10 EXHAUST SYSTEMS - GENERAL EXHAUST
 - 3.12.11 NIGHT SHUT DOWN
- 3.13 LABORATORIES
 - 3.13.1 INDOOR DESIGN CONDITIONS
 - 3.13.2 SUPPLY AIR
 - 3.13.3 AIR PRESSURE RELATIONSHIP
 - 3.13.4 EMERGENCY POWER REQUIREMENTS
 - 3.13.5 ORTHOTIC LABORATORIES
 - 3.13.6 DRY LABORATORIES
 - 3.14 LAUNDRY (CENTRAL) FACILITY
 - 3.14.1 GENERAL
 - 3.14.2 ENERGY CONSERVATION
 - 3.14.3 COORDINATION
 - 3.15 LINEAR ACCELERATORS
 - 3.15.1 INDOOR DESIGN CONDITIONS
 - 3.15.2 EMERGENCY POWER REQUIREMENTS
 - 3.15.3 SPECIFIC REQUIREMENTS
 - 3.16 MEDICAL MEDIA SERVICE (MMS)
 - 3.16.1 GENERAL
 - 3.16.2 HVAC REQUIREMENTS
 - 3.16.3 CORE AREAS
 - 3.16.4 EXPANDED CORE AREAS
 - 3.16.5 HVAC SYSTEM FEATURES
 - 3.17 MRI (MAGNETIC RESONANCE IMAGING) UNITS AND CT SCANNERS
 - 3.17.1 GENERAL
 - 3.17.2 INDOOR DESIGN CONDITIONS
 - 3.17.3 EMERGENCY POWER REQUIREMENTS
 - 3.17.4 HVAC SYSTEMS
 - 3.18 PSYCHIATRIC AREAS
 - 3.18.1 INDOOR DESIGN CONDITIONS
 - 3.18.2 SUPPLY AIR
 - 3.18.3 SPECIAL CONSIDERATIONS
 - 3.18.4 EXCEPTION
 - 3.19 SHIELDED ROOMS
 - 3.19.1 GENERAL
 - 3.19.2 LEADED SHIELDED DUCT REQUIREMENTS
 - 3.20 SPD (SUPPLY, PROCESSING AND DISTRIBUTION)
 - 3.20.1 GENERAL
 - 3.20.2 INDOOR DESIGN CONDITIONS
 - 3.20.3 SUPPLY AIR
 - 3.20.4 EMERGENCY POWER REQUIREMENTS
 - 3.20.5 REFERENCE DOCUMENT
 - 3.20.6 ETO EXHAUST SYSTEM
 - 3.20.7 SPECIAL SPD EXHAUST SYSTEM
 - 3.20.8 GENERAL SPD EXHAUST SYSTEM
 - 3.21 SURGERY SUITE SYSTEMS
 - 3.21.1 GENERAL
 - 3.21.2 INDOOR DESIGN CONDITIONS
 - 3.21.3 SUPPLY AIR
 - 3.21.4 EMERGENCY POWER REQUIREMENTS
 - 3.21.5 SYSTEM DESCRIPTION

- 3.21.6 AIRHANDLING UNITS (AHU'S)
- 3.21.7 AIR DISTRIBUTION
- 3.21.8 MISCELLANEOUS

3.22 TB CRITERIA

- 3.22.1 GENERAL
- 3.22.2 REFERENCE DOCUMENTS
- 3.22.3 POLICY AND PROCEDURES
- 3.22.4 BASIC DESIGN PARAMETERS
- 3.22.5 AIR HANDLING SYSTEMS (EXISTING
AND NEW FACILITIES)

3 HVAC REQUIREMENTS FOR OCCUPIED AREAS

3.1 AMBULATORY CARE - EVALUATION AND EMERGENCY AREA

3.1.1 GENERAL

(a) See [Article 1.3](#) for indoor design conditions and exhaust requirements for individual rooms.

(b) Provide a dedicated HVAC system to serve the evaluation and emergency areas, including Minor Operating Rooms (O.R.s). The air-handling unit shall operate 24 hours a day.

3.1.2 MINOR O.R. (Trauma Room)

Discuss with the medical center the need for full operating room HVAC requirements. The HVAC systems for the Minor O.R.s (Trauma Rooms) shall have the following features:

(a) Constant volume air supply for O.R.s. The remaining spaces of the emergency suite can have variable air volume supply

(b) 100 percent exhaust of the supply air

(c) Individual room temperature control

(d) Individual room humidity control is not required

(e) Conventional overhead supply and exhaust air distribution. Special air distribution, specified for the conventional O.R.s, is not required

(f) Maintain positive pressure in O.R.

3.2 AMBULANCE ENTRANCES

3.2.1 GENERAL

Ambulance entrances are required. They shall be enclosed where the outdoor design temperature is below -12 degrees C (10 degrees F), as listed in the 99 percent column of Table 1, ASHRAE Handbook - Fundamentals. Provide a minimum of 10 air changes per hour of exhaust air.

3.2.2 SPECIAL DESIGN CONSIDERATIONS

(a) Exhaust fan shall be activated automatically whenever ambulance enters, and continues to operate for five minutes after ambulance leaves. Provide 0-15 minutes time delay.

(b) Provide thermostat to cycle the exhaust fan when the indoor space temperature exceeds 29 degrees C (85 degrees F).

(c) Provide outdoor air intake with power operated damper for exhaust fan make-up air.

(d) Provide bottom wall register close to the rear of ambulance entrance for half of exhaust and a ceiling register for the other half.

(e) Provide ceiling mounted electric radiant heater, of minimum 10 kW capacity, at the rear of the ambulance entrance to maintain 15 degrees C (60 degrees F) (minimum) in room without ventilation.

3.3 ANIMAL RESEARCH FACILITY

3.3.1 GENERAL

(a) Indoor Design Conditions for Animal Rooms:

Summer: 18 degrees C (65 degrees F) Db, 60 Percent RH (±5 Percent)

Winter: 29 degrees C (85 degrees F) Db, 30 Percent RH (±5 Percent)

(b) All supply and exhaust fans, water chillers, chilled water circulating pumps and automatic temperature controls shall be on emergency power.

(c) See Veterinary Medicine Unit (VMU) Design Guide for information for other areas.

3.3.2 SPECIFIC REQUIREMENTS

(a) Provide a 100 percent outdoor air, constant volume (single or dual duct) HVAC system. Provide multiple systems, if necessary.

(b) Provide exhaust filter grilles with one-inch thick surface mounted filter, at approximately seven inches above the finished floor, in animal holding area.

(c) See [Article 2.12](#) for the requirement of the dedicated refrigeration equipment.

(d) Coordinate locations, sizes, and types of fume hoods with the equipment layouts shown on the architectural detail drawings and provide appropriate exhaust system(s) in accordance with the requirements described in [Article 2.11](#).

(e) Control valves for preheat and reheat coils shall be normally closed (NC).

(f) Provide local space temperature alarms (high and low) at the animal holding areas and at ECC. Coordinate location of local alarms with the medical center.

3.3.3 ANIMAL OPERATING ROOMS

The HVAC requirements are the same as for the human operating rooms with the following exceptions:

(a) Indoor temperature and humidity recorders are not required.

(b) Supply air ducts need not be constructed from stainless steel.

(c) Exhaust air grilles may be located at the floor or ceiling level.

3.3.4 CAGE WASHERS

(a) Provide a dedicated exhaust system by placing a canopy (VA Type A) hood over the cage washer to remove moist air when the cage washer is operating. When cage washer door(s) are open (get signal from washer control panel) air shall be exhausted through the washer 125 Pa (1/2-inch

water column) static pressure drop). Provide motorized on-off control dampers between the washer exhaust and the Type A hood. Provide an airflow control valve to ensure airflow through the hood.

(b) Coordinate utility requirements for the cage washer with PG-18-6, "Equipment Reference Manual."

3.4 AUDIOLOGY SOUND SUITES

3.4.1 NOISE CRITERIA

Sound level: NC 25

3.4.2 SPECIFIC REQUIREMENTS

(a) Provide a dedicated air terminal unit, (constant volume or variable air volume) with reheat coil, to serve the examination and control rooms. Locate the room thermostat in the control room.

(b) Supply at least 2.8 Cu M/Min (100 CFM) in each room. With a variable air volume system, the reduction in air volume shall be limited to 25 percent of the design airflow.

(c) In the absence of the building HVAC supply air systems, investigate the possibility of using pre-fabricated, engineered, ventilation system supplied by the sound suites manufacturers.

3.5 AUDITORIUMS AND THEATERS

3.5.1 GENERAL

(a) Minimum outdoor air requirements based on ASHRAE Standard 62-1999, but shall not be less than 15 percent of the supply fan air volume.

3.5.2 HVAC REQUIREMENTS

(a) Provide a dedicated, constant volume air-handling unit for auditoriums and theaters. The air-handling unit shall have an economizer cycle capability.

(b) Size air outlets/inlets to maintain specified room NC35 level.

(c) Sound attenuators and prefabricated acoustical units shall be used, as required, to curb duct and equipment noises and maintain predetermined NC35 level.

(d) Locate return air outlets at 300 mm (12 inch) above finished floor for proper air circulation.

3.6 BONE MARROW TRANSPLANT (BMT) PATIENT AREAS

3.6.1 GENERAL

(a) Indoor Design Conditions for Patient Areas:

Summer: 24 degrees C (76 degrees F) Db, 50 percent RH

Winter: 25 degrees C (78 degrees F) Db, 30 percent RH

(b) Supply a minimum of 18 air changes per hour for BMT Special Areas, Patient Rooms, Donor Rooms, Recovery Rooms, and Medical Preparation Rooms.

(c) Maintain positive pressure in the patient areas.

(d) HVAC equipment serving BMT areas shall be on emergency power.

(e) AIR HANDLING UNIT SELECTION: Provide a dedicated air handling unit and exhaust system to serve the Bone Marrow Unit comprising of the patient rooms, donor rooms, recovery room, nurse's station, conference room and other associated areas, such as circulation, lounge, toilets, etc. The unit shall run 24 hours a day.

(f) TEMPERATURE CONTROL: For all special areas, including patient rooms, recovery rooms, donor rooms and medical preparation rooms, the supply air quantity shall be allowed to remain constant and the space temperature shall be maintained by controlling the reheat coils at the air terminal units and the perimeter heat, if provided. For the remaining areas, the variable air volume terminals with or without reheat coils may be used. The need for a volumetric control for the supply air fan should be determined on the basis of the air balance calculations.

3.6.2 SPECIAL CONSIDERATIONS

It is essential to maintain an environment with minimum airborne fungal pathogens in the patient and recovery rooms. These spaces shall be sealed by the anterooms. To accomplish this task, the following special features should be incorporated in the HVAC system design.

(a) AIR FILTERS: For each patient and recovery room, supply air duct-mounted HEPA filters with 99.97 percent efficiency and @ 0.3 micron particle shall be provided to arrest any opportunistic fungal which may have been dislodged from the air handling unit due to interruption of air flow during scheduled maintenance. The duct HEPA filters shall be located on the downstream side of the supply air terminal unit. The selection of the filters should be such that the air static pressure drop through it is kept minimum.

(b) AIR DISTRIBUTION: The air distribution in the patient and recovery rooms shall be such that only the supply air outlets shall be installed in these occupied space. Exhaust of these rooms shall be through the anterooms. The anterooms of the occupied spaces shall be ventilated by installing the exhaust air inlets only. With this arrangement, the patient room air would flow from the occupied spaces to the anterooms. The anterooms shall also draw air from the adjacent corridor, and shall be maintained under negative pressure with respect to the occupied areas and corridors. The amount of air drawn from the corridors shall, however, be relatively less and shall be only 10 percent of the air drawn from the occupied spaces.

(c) AIR PRESSURE: Each patient and recovery room shall be kept under positive pressure by retaining at least 15 percent of the supply air. To ensure exact air balance, either an air flow control valve or a constant volume box, with factory set air volume, shall be provided in the exhaust air duct takeoff from each anteroom and all other exhaust air connections of the dedicated system.

3.7 CT SCANNER

3.7.1 GENERAL

(a) The CT scanner has a function similar to the MRI unit; both being full body tomography units. The CT is, however, less sophisticated compared to the MRI.

3.7.2 INDOOR DESIGN CONDITIONS

Summer: 24 degrees C (76 degrees F) Db, 50 percent RH

Winter: 25 degrees C (78 degrees F) Db, 30 percent RH

3.7.3 EMERGENCY POWER REQUIREMENTS

(a) HVAC equipment serving CT scanner area shall be on emergency power.

3.7.4 CT SCANNER HVAC SYSTEMS

3.7.4.1 Environmental Unit:

(a) Provide a dedicated air-handling unit to serve the CT Suite. The capacity of the air-handling unit shall be based on the actual internal heat gain (equipment load, occupancy, and light load) and indoor design conditions per the CT unit manufacturer.

(b) Coordinate the lead lining, if needed, per requirements for the HVAC ductwork in Examination Room, with the architect and the equipment manufacturer.

(c) The air-handling unit should shut down during unoccupied hours.

3.7.4.2 Computer Unit: An air-handling unit shall be provided for the cooling of CT Scanner and the associated computer room. The unit capacity and specific requirements shall be established in consultation with the equipment manufacturer.

3.7.4.3 Air-cooled chiller: Provide an air-cooled chiller for the environment and computer units. Also, connect these two units with central chilled water system as a back up.

3.8 COMPUTER ROOMS

3.8.1 GENERAL

The HVAC system shall be a free standing, factory-packaged, A/C unit specially designed for computer rooms.

3.8.2 INDOOR DESIGN CONDITIONS

Summer: 21 degrees C (70 degrees F) Db, 40 percent RH (± 5 percent)

Winter: 21 degrees C (70 degrees F) Db, 40 percent RH (± 5 percent)

3.8.3 CONSTRUCTION STANDARD

See Construction Standard 866-1 for additional design parameters.

3.8.4 EMERGENCY POWER REQUIREMENTS

HVAC equipment serving computer rooms shall be on emergency power.

3.8.5 HVAC SYSTEM DESCRIPTION

(a) The HVAC system for the Uninterruptible Power Supply (UPS) shall be based on a conversion of 9.75 kW (3.0 tons) = 2 KVA for UPS power.

(b) Provide at least one back-up A/C unit in the computer room.

(c) Use underfloor space as an air distribution plenum. Provide 450 mm (18 inches) clear space for new buildings and a minimum of 300 mm (12 inches) clear space for existing buildings. Coordinate this requirement with the architect.

(d) Provide a water detection system, with an alarm device, to detect moisture in the plenum below the raised deck.

3.8.6 SPECIAL CONSIDERATIONS

Consider the following features into the design of HVAC system:

(a) Automatic controls with alarm warning when 65 percent maximum relative humidity under the floor is reached.

(b) Built-in redundancy by use of multiple refrigeration circuits or multiple air-handling units

(c) Downflow to feed underfloor air distribution system

(d) Noise level NC 35

3.9 DENTAL PROSTHETICS LABORATORY

3.9.1 COOLING LOAD

Cooling load requirements for the laboratory and ceramics room shall be as follows:

(a) Laboratory 0.70 Watts/Sq M (6.0 Watts/Sq Ft); Ceramics Room 1.3 Watts/Sq Ft (12.0 Watts/Sq Ft).

(b) Internal heat load due to laboratory equipment and gas burners, etc. is factored in the lighting load.

3.9.2 CERAMICS ROOM

(a) Maintain positive pressure in the room.

(b) Provide wall mounted exhaust registers at or near the technician workbenches. Coordinate location(s) with the architect.

3.9.3. LABORATORY

(a) Exhaust 11 Cu M (400 CFM) (minimum) from the prosthetic dental workstation by installing wall registers at table height or through a canopy type hood. Exhaust air can be taken through a general exhaust system. The hood location shall be shown on, and in coordination with, the architectural equipment drawings.

(b) Assume 745 W (1.0 HP) fan motor internal heat gain per each dental technician bench. Each bench is to be equipped with a built-in dust collector through which the room air is to be recirculated.

(c) Provide a general exhaust system through Type A canopy hoods, sized at 0.5 m/s (100 fpm) face velocity over the boil-out sink and casing-soldering areas. A portion of the exhaust duct between the boil-out sink and general exhaust ductwork shall be constructed of stainless steel or non-corrosive material. If the room air is short of the exhaust requirements, increase the air handling unit capacity accordingly, to provide additional air quantity. Draw approximately 15 percent of the total exhaust air from the adjoining corridor.

3.10 INTENSIVE CARE UNITS (ICUs)- Medical, Surgical and Coronary

3.10.1 INDOOR DESIGN CONDITIONS

Summer: 22 degrees C (72 degrees F) Db, 50 percent RH

Winter: 25 degrees C (78 degrees F) Db, 30 percent RH

3.10.2 SUPPLY AIR

Maintain minimum 8 air changes per hour.

3.10.3 PRESSURE RELATIONSHIP

Maintain positive pressure in the room.

3.10.4 EMERGENCY POWER REQUIREMENTS

HVAC equipment serving ICU's shall be on emergency power.

3.10.5 SPECIAL REQUIREMENTS

(a) Provide a dedicated air-handling unit for ICU ward of larger than 5 beds. Where there are approximately five (5) ICU beds or less, a dedicated unit may be omitted, and these rooms may be served from another building HVAC system provided the system meets filtration requirements for ICUs and all supplied air is exhausted to outdoors. In existing buildings where it's not practical to exhaust 100 percent from the ICUs, air shall be re-circulated through HEPA filters with a caution that HEPA filters should be installed at the air-handling units only. HEPA filters installed in branch return air duct will create air balance problem.

(b) If ICUs are equipped with individual toilets for each bed, each toilet shall be exhausted at the rate of 2.2 Cu M/Min (80 CFM).

(c) Provide individual temperature room controls for ICU Bed Rooms.

(d) Provide a special dedicated exhaust system for the Isolation Room in accordance with the VA Standard Detail 15900-7 and [Article 2.11](#), "Exhaust Systems."

(e) Provide a status alarm for the HVAC fans at the nursing station when the Engineering Control Center (ECC) is not available.

3.11 ISOLATION ROOMS

(a) Separate negative and positive pressure rooms are required. See [Article 2.11.6](#).

(b) See [Table 3-5](#) and [Table 3-6](#) for TB isolation rooms.

3.12 KITCHENS (MAIN) AND KITCHENS FOR LARGE CAFETERIAS

3.12.1 GENERAL

Requirements listed below do not apply to small satellite kitchenettes or cafeterias generally used for food warm-up. Provide general and special dedicated exhaust systems to serve kitchen environment and equipment. Coordinate sizes, capacities, and locations of the HVAC equipment and hoods with the kitchen equipment layouts shown on the architectural drawings and the VA Equipment Reference Manual PG-18-6.

3.12.2 INDOOR DESIGN CONDITIONS

Summer: 27 degrees C (82 degrees F) Db, 60 percent RH.

Winter: 21 degrees C (70 degrees F) Db. Humidity control not required.

3.12.3 SUPPLY AIR

Supply a minimum of 10 air changes per hour.

3.12.4 EXHAUST AIR

The exhaust air requirements shall be coordinated with the equipment specifications.

3.12.5 AIR PRESSURE RELATIONSHIP

Maintain negative pressure in the kitchen area. Air pressure in the scullery and dishwashing areas shall be negative at all times in relation to the rest of the kitchen areas. The clean dish area shall be positive relative to the dirty or dishwashing areas.

3.12.6 NOISE CRITERIA

Noise level: NC 50

3.12.7 EXHAUST SYSTEMS, KITCHEN HOODS

The exhaust systems are classified depending upon the type of application, that is, the hoods for the grease producing equipment or hot vapor producing equipment. See VA Master Specifications, Section 11420. See Design Program Guide PG-18-6 for equipment details.

3.12.7.1 GREASE PRODUCING EQUIPMENT: The hoods for grease producing equipment, such as griddle, ovens, broilers, deep fat fryers, etc., are generally fabricated by the kitchen equipment manufacturers. The hoods are high velocity type with make-up air arrangement. The exhaust systems shall have the following specific requirements:

(a) The make-up air shall not be heated or cooled but shall be filtered by VA Grade "D" (30 percent efficient) filters before it is supplied to the hood at the rate of 2.8 Cu M/Min (100 CFM) per slotted linear millimeter (foot) of hood and at the discharge slot velocity of 5 m/s (1000 fpm). Assume 37 Pa (0.15 inch water column) static pressure drop through the hood.

(b) The exhaust air from the hood shall be removed at the rate of 7 Cu M/Min (250 CFM) per slotted linear foot and the static pressure drop through the hood shall be assumed as 330 Pa (1.33 inches of water column).

(c) The difference between the exhaust and make-up air quantities amounting to 4.2 Cu M/Min (150 CFM) per linear foot of the slotted

perimeter shall be derived from the environmental air supplied to the kitchen and/or dining room air-handling units.

(d) Coordinate manual and automatic operation of the exhaust fan with the hood control panel (furnished with the hood) for washroom cycle and fire protection.

(e) The design of the grease hood exhaust system shall incorporate the following fire and safety features:

(1) The exhaust ducts shall lead as directly as possible to the exterior of the building, and discharge the air above the highest level of the building. The exhaust ducts shall not pass through the fire walls (3 hours rating) or 2-hour fire partitions.

(2) The exhaust system serving the grease hoods shall not be connected to any other exhaust ducts or building exhaust systems. As far as possible, each grease hood shall have a dedicated exhaust fan and ductwork.

(3) The air velocity through the exhaust duct shall not be less than 7.6 m/s (1500 feet per minute).

(4) For the purpose of cleaning and inspection, openings (clean-outs) shall be provided in exhaust duct at each change in duct direction and in horizontal duct rooms at 3 m (10 ft) intervals.

(5) The material, fabrication, and installation of the exhaust ducts carrying grease-laden air shall comply with the provisions outlined in NFPA 96. See VA master specification Section 15250 for specifying UL listed fire rated insulation for grease carrying exhaust air ducts.

(6) Volume dampers and fire/smoke dampers shall not be installed in exhaust ducts.

(7) The termination of ducts shall be such that:

(aa) The discharge of exhaust air shall be kept away from the roof surface.

(bb) A minimum distance of 1000 mm (40 inches) shall be maintained between the roof surface and the outlet.

(cc) A minimum distance of 3 m (10 ft) shall be maintained between the discharge air outlet and adjacent buildings, air inlets, property lines, and adjoining grade levels.

(8) The environmental air ducts shall not be located in the same chase carrying the grease exhaust air duct. See [Paragraph 2.11.2.2](#).

3.12.7.2 HOT VAPOR PRODUCING EQUIPMENT: The hoods (high velocity type) for hot vapor producing equipment, such as, steam kettles, vegetable steamers, and high pressure cookers, etc., are either fabricated by the kitchen equipment manufacturers or of canopy type fabricated by the mechanical contractor. Make-up and exhaust air requirements for hoods furnished by manufacturer shall be the same as those outlined under (paragraph 3.12.7.1 items (a) through (d)). The remaining provision, subparagraph (e) under Paragraph 3.12.1 is not applicable to the exhaust systems for hot vapor

equipment. With the canopy type hoods, the exhaust air quantity shall be based at the rate of 1.4 to 2.8 Cu M/Min (50 to 100 CFM) per square foot of the hood area. The environmental air from the kitchen and other occupied places shall be used as make-up air for the exhaust. The exhaust air ductwork shall be constructed of stainless steel.

3.12.8 EXHAUST SYSTEMS - WET EXHAUST

The moist air over pot/pan and dishwasher should be captured by using either canopy (Types A, B, C) hoods or any other similar hoods furnished by the dishwashing equipment manufacturers. See VA Standard Detail 15840-22. The exhaust air quantity shall be based at the rate of 1.4 to 2.8 Cu M/Min (50 to 100 CFM) per square foot of the hood area. The environmental air from the kitchen and other occupied areas shall be used as make-up air for the exhaust. The exhaust air ductwork shall be constructed of stainless steel.

3.12.9 HOT AIR DISCHARGE

Hot air discharge from baking and cooking ovens shall not be connected directly to ductwork. Provide canopy exhaust hoods or grilles over hot air discharge.

3.12.10 EXHAUST SYSTEMS - GENERAL EXHAUST

Depending upon the remaining available environmental air for exhaust, general exhaust arrangement shall be provided through ductwork and ceiling mounted registers/grilles over the heat producing equipment, such as refrigeration compressors, plate warmer, mixers, etc. The exhaust air duct can be connected to the wet exhaust duct system. The actual system configuration and the system air balance will depend upon the specific project parameters and may vary from project to project.

3.12.11 NIGHT SHUT DOWN

Since most or all of the heat producing equipment will be inoperative at night, the quantity of supply and exhaust air shall either be reduced or stopped. However, a neutral air pressure shall be maintained in the area. Supply air need not be cooled at night.

3.13 LABORATORIES

3.13.1 INDOOR DESIGN CONDITIONS

Summer: 24 degrees C (76 degrees F) Db, 50 percent RH
Winter: 22 degrees C (72 degrees F) Db, 30 percent RH

3.13.2 SUPPLY AIR

Maintain minimum 12 air changes per hour.

3.13.3 AIR PRESSURE RELATIONSHIP

Maintain negative pressure in Laboratories.

3.13.4 EMERGENCY POWER REQUIREMENTS

All laboratory hoods exhaust fans for H3, H7 and H12 (B1 and B2 only), H13 and H14 hoods shall be on emergency power.

3.13.5 ORTHOTIC LABORATORIES

3.13.5.1 GENERAL: Coordinate ventilation requirements with the equipment layout shown on the architectural drawings.

3.13.5.2 EXHAUST SYSTEMS: The number and type of exhaust systems will depend upon the size and function of the equipment used in the laboratory. The following systems are to be provided:

(a) **GENERAL EXHAUST:** Provide an exhaust air duct connection from the Infra Red Curing Oven. The oven is equipped with an integral blower. The blower picks environmental air to discharge into the general exhaust duct. Provide an air gap between the blower discharge duct and the general exhaust duct. This oven is a VA furnished and VA installed item.

(b) **SPECIAL EXHAUST**

(1) Provide a dedicated exhaust system to remove toxic chemical fumes, generated by plastics and resins, over the plastics work area table.

(2) The work area table shall be provided with a canopy hood (Type A, B, or C). The exhaust air quantity shall be based on 0.26 to 0.51 m/s (50 to 100 fpm) face velocity over the hood area.

(3) The ductwork shall be of corrosion resistant material or stainless steel. The fan shall be of spark-proof construction material with explosion proof motor.

(4) The exhaust air shall be discharged at the highest point above the building.

(5) Special exhaust fans shall be on emergency power. [See Article 2.16.](#)

(c) **WELDING EXHAUST:** For welding area, provide a pre-fabricated, engineered exhaust system complete with special air inlets, flexible ductwork, solid sheet metal ductwork, exhaust fan, etc., to make a complete system. The size and capacity of the welding system depends upon the extent of welding activity, the number and locations of the special air inlets and special requirements, if any, of the medical center.

3.13.6 DRY LABORATORIES

Some of the total laboratory unit space may be designated as "Dry Laboratories" on a project-to-project basis. Although dry laboratories contain standard laboratory casework, they do not require any fume hoods or any special HVAC requirements such as 100 percent outdoor system or negative pressure etc. These labs are used only for research and may contain some electronic equipment. HVAC systems for these labs shall be similar to that of conference rooms.

3.14 LAUNDRY (CENTRAL) FACILITY

3.14.1 GENERAL

3.14.1.1 Provide ventilation, evaporative cooling or mechanical cooling to in the Laundry to maintain following temperatures and pressure.

Summer: 28 degrees C (84 degrees F) Db, 60 percent RH

Winter: 19 degrees C (68 degrees F) Db, uncontrolled humidity

Pressure: Negative

3.14.1.2 Provide night and weekend heating. Maintain 7 degrees C (45 degrees F). Unit heaters may be used for this propose.

3.14.1.3 The soiled linen area shall be kept under negative pressure relative to the clean linen area and other surrounding areas at all times.

Table 3-1 Ventilation Requirements for Laundry

Area	Pressure	Minimum Outdoor Air Changes/Hr	Minimum Air Changes/Hr of Supply Air	All Air Exhausted
Laundry, General	Negative	2	10	Yes
Soiled Linen	Negative	-	10	Yes
Clean Linen	Positive	-	2	No

3.14.2 ENERGY CONSERVATION

(a) Use a lint filter and make-up air systems to clean and recirculate the hot dryer exhaust air back to the dryer utilizing the dryer blower.

(b) Provide heat recovery systems, wherever feasible, for maximum energy conservation.

(c) Air change rate may be reduced during heating and cooling seasons.

(d) Insulate heat-producing equipment, where practical, to reduce the temperature in occupied areas.

3.14.3 COORDINATION

Coordinate utility requirements and heat gain from the actual equipment submittals with HVAC calculations for the laundry.

3.15 LINEAR ACCELERATORS

3.15.1 INDOOR DESIGN CONDITIONS

Summer: 24 degrees C (76 degrees F) Db, 50 percent RH

Winter: 25 degrees C (78 degrees F) Db, 30 percent RH

3.15.2 EMERGENCY POWER REQUIREMENTS

Closed loop water chilling equipment for Linear Accelerators shall be on emergency power.

3.15.3 SPECIFIC REQUIREMENTS

3.15.3.1 CAPACITY DATA: The heat dissipation and internal cooling requirements vary with the make of the linear accelerators. Check with the equipment manufacturer for cooling requirements.

(a) The heat dissipated to the space during idle and working cycles of the linear accelerator.

(b) The amount of internal cooling required for the equipment.

(c) The cooling shall be provided by circulating cold water at 551 kPa (80 Psig) (maximum inlet pressure) and at an inlet temperature between 10 to 29 degrees C (50 to 86 degrees F). Use closed-loop, dedicated air-cooled chiller for supplying the water. The use of the city water is not permitted. See [Article 2.12.9](#) for the dedicated refrigeration system.

3.15.3.2 EXHAUST SYSTEMS: Provide separate and dedicated exhaust systems to ventilate the biological safety cabinets and canopy hoods.

(a) Biological safety cabinets: Coordinate locations and type of the safety cabinets with the architectural equipment drawings and provide exhaust systems in accordance with the guidelines given in [Article 2.11.3](#).

(b) Canopy Hoods: Coordinate location and size of hoods with the architectural equipment drawings. Provide a dedicated exhaust system to remove harmful gases produced during cutting of the styrofoam blocks underneath the hood. Establish exhaust air quantity at the rate of 0.51 m/s (100 fpm) air velocity over the hood face area. Provide round welded ductwork to avoid duct leakage. Ductwork should be arranged to avoid interference with the overhead hoistway.

(c) All water piping, including drain lines must be kept away from areas above linear accelerators and associated control equipment to prevent water damage.

3.16 MEDICAL MEDIA SERVICE (MMS)

3.16.1 GENERAL

Medical Media Service is comprised of core spaces (functions) and or expanded core spaces. The actual program and required space depends upon the number of employees, individual medical center needs, and/or VISN support. In the following paragraphs, the Special and General HVAC requirements are defined and the spaces to which they are applicable have been identified.

3.16.2 HVAC REQUIREMENTS

3.16.2.1 Indoor Design Conditions

(a) Special:

- (1) Summer and Winter: 68 to 72 Degrees F Db.
- (2) Summer: 60 percent Relative Humidity (Uncontrolled)
Winter: 30 percent Relative Humidity (Zone Control)

(b) General:

- (1) Summer: 76 to 78 Degrees F Temperature, 60 percent Relative Humidity (Uncontrolled).
- (2) Winter: 70 to 72 Degrees F Dry-Bulb Temperature, 30 percent Relative Humidity (Zone control)

(c) Notes:

- (1) If the MMS is equipped with Video Editing/CCTV Control Suite (Expanded Core Space), the maximum space temperature shall not exceed 68 degrees F.
- (2) Winter humidification control is required at the air-handling unit; do not provide any room humidity control.

3.16.2.2 Supply Air

- (a) Special: 12 air changes per hour minimum
- (b) General: 6 air changes per hour minimum
- (c) Provide more air changes/hour if required, to meet the space sensible cooling load demand.

3.16.2.3 Exhaust/Recirculation

- (a) Special: 100 percent exhaust of the supply air.
- (b) General: Recirculation of room air is permitted provided the air handling unit design permits recirculation of room air during mild weather.

3.16.2.4 Air Pressurization Requirements

- (a) Special: Negative air pressure. (Exhaust/Return air = Supply air + 15 percent)
- (b) General: Zero air pressure (Supply and return air volumes shall be the same).

3.16.2.5 Room Temperature Control

- (a) Special: Individual room temperature control is required.
- (b) General: Individual room temperature control is not required.

3.16.3 CORE AREAS

See [Table 3-2](#)

3.16.4 EXPANDED CORE AREAS

See [Table 3-3](#)

3.16.5 HVAC SYSTEM

3.16.5.1 A dedicated, all air, constant volume air handling unit shall be provided to service the MMS. The air-handling unit shall have the following features.

- (a) Double wall construction.
- (b) Horizontal (or vertical), draw thru, single zone configuration. Blow thru configuration will not be acceptable.
- (c) 30 percent ASHRAE Test Efficiency pre-filters and 85 percent ASHRAE Test Efficiency after-filters. These filters can be located back to back, on the suction side of the supply air fan, in a common housing.
- (d) Energy Efficient Motor.

(e) Return Air System:

(1) The return air system shall be used if the return air volume is at least 35 percent of the total supply air volume. When the return air volume is below 35 percent of the total supply air volume, the air-handling unit shall use 100 percent outdoor air and the total supply air volume shall be fully exhausted outdoors.

(2) With a return air system, a return air fan shall be used to ensure proper air balance, if deemed necessary. The air handling unit shall be equipped with an economizer cycle for "free cooling" to conserve energy.

3.16.5.2 Cooling: The MMS air handling unit shall be served by a dedicated air-cooled chiller to ensure the lower cooling temperatures required in the space. Air-cooled chiller will also ensure availability of chilled water whenever the central chilled water plant is not operating.

3.16.5.3 Heating: For heating, steam from the central boiler plant and/or hot water generated by the steam to hot water heat exchangers shall be used. For locations qualifying for perimeter heating, finned tube radiation or overhead radiant ceiling panels shall be provided. The perimeter heating shall be controlled by the room thermostat such that cooling and heating do not come on line together. See [Paragraph 2.7.2](#).

3.16.5.4 Exhaust System: A dedicated general exhaust system shall be provided to service the MMS. The exhaust air system shall be interlocked with the air-handling unit.

Table 3-2 Medical Media Service - Core Areas

Room Name	Indoor Design Conditions	Air Changes/Hr	Exhaust/Recirculation Air	Air Pressure	Room Temperature Control
Darkroom	Special	Special	Special	Special	Special
Darkroom (Printing & Enlarging)	Special	Special	Special	Special	Special
Photo Finishing	Special	Special	Special	Special	Special
Photo Studio/A.V. Recording (See Notes (a) and (b))	General	General	General	General	Special
Photo Micrography	Special	Special	Special	Special	Special
Camera Copy	Special	Special	Special	Special	Special
Audio Visual Equip. Storage /Checkout (See Note (c))	General	General	General	General	General

Room Name	Indoor Design Conditions	Air Changes/Hr	Exhaust/ Recirculation Air	Air Pressure	Room Temperature Control
Chief's Office	General	General	General	General	Special
Reception/Secretary (See Note (d))	General	General	General	General	General
Corridor (See Notes (e)& (f))	General	General	General	General	General

NOTES:

(a) A.V. Recording room is also known as the A.V. Production Room. Still photography and Video Recording Studio is also defined as the A.V. Production Room.

(b) These rooms have a substantial light load and other internal heat gain due to equipment. Allowance must be made for the heat generated by the lights and equipment based on the actual equipment installed. Minimum heat load = 3000 W (10,000 BTUH).

(c) This space can be combined with the corridor or other circulation area, if feasible, to form a temperature control unit.

(d) If this area directly communicates with the corridor space, the corridor can be included in the temperature control zone.

(e) The air supplied to the corridor is used as make-up for maintaining negative air pressure in the adjoining areas. Therefore, if air quantity in excess of four air changes per hour is required in the corridor, the supply air volume shall be increased accordingly.

(f) The toilets and janitors closets connected to the corridor shall also use the corridor air as make-up for their exhaust needs. These areas shall be exhausted outdoors at the rate of 10 air changes per hour. Ducted supply air shall not be introduced in these spaces. Note that the toilets do not require any room temperature control in the cooling mode. For winter heating, thermostatically controlled terminal heating devices shall be provided for exterior toilets.

Table 3-3 Medical Media Service - Expanded Core Areas

Room Name	Indoor Design Conditions	Air Changes/Hr	Exhaust/ Recirculation Air	Air Pressure	Room Pressure Control
Stat Camera	Special	Special	Special	Special	Special
Illustration Room (See Notes (d) and (e))	Special	Special	Special	Special	Special
Illustration Prep. Room (See Note (c))	Special	Special	Special	Special	Special
Video Editing CCTV Control Room (See Notes (d) & (e))	Special	Special	Special	Special	Special
Computer Imaging System Network (CISN) (See Notes (e) & (f))	Special	Special	Special	Special	Special
Client Review Room (See Note (g))	General	General	General	General	Special

NOTES:

(a) The exhaust air can be taken through a prefabricated spray booth if the scope of work includes such a system. Its location and capacity should be coordinated with the architectural drawings. Assume approximately 5 Cu M/Min (160 CFM) through each inlet hose connection for systems comprising of 1 to 3 hoses.

(b) The exhaust air register 200 mm x 150 mm (8 inch x 6 inch) size with 4 Cu M/Min (150 CFM) capacity mounted at the counter height to remove air from the work area. Coordinate location with the architectural drawings. Note that all counters do not require exhaust air registers.

(c) Coordinate the exhaust requirements with the architectural drawings as this area is supposed to be equipped with modified (without gas and vacuum outlets) H7 hood. Provide a dedicated exhaust system for fume hoods.

(d) Room temperature shall not exceed 20 degrees C (68 degrees F).

(e) The internal heat gain due to equipment and lights should be estimated to 3000 W (10,000 BTUH), when actual heat loads are not available.

(f) The rooms are generally planned in two different sizes, 16 Sq M (180 Sq Ft) and 28 Sq M (300 Sq. Ft).

(g) Depending upon the room size, the space internal heat gain, including light load, should be estimated as follows:

16 Sq M (180 Sq. Ft) room size = 1,800 W (6,000 BTUH).

28 Sq M (300 Sq. Ft) room size = 2,400 W (8,000 BTUH).

(h) The internal heat gain due to equipment should be coordinated with the architectural equipment drawings.

3.17 MAGNETIC RESONANCE IMAGING (MRI), UNITS AND CT SCANNERS

3.17.1 GENERAL

3.17.1.1 HVAC requirements for the MRI suite vary widely with the capacity and make of the imaging unit. Information pertaining to indoor design conditions, internal heat gain, and shielding against the Radio Frequency (RF) and EMI (Electro-Magnetic Interference) etc. shall be obtained from the equipment manufacturer during design development phase of the design project.

3.17.2 INDOOR DESIGN CONDITIONS

Summer: 24 degrees C (76 degrees F) Db, 50 percent RH

Winter: 25 degrees C (78 degrees F) Db, 30 percent RH

3.17.3 EMERGENCY POWER REQUIREMENTS

HVAC equipment for MRI Suites shall be on emergency power.

3.17.4 HVAC SYSTEMS

3.17.2.1 ENVIRONMENTAL UNITS: Provide a dedicated, air-handling unit to serve the examination room and other spaces associated with the MRI suite. Depending upon the specific needs of various spaces, conditioned air shall be supplied by either constant or variable air volume terminal units serving as temperature control zones. Note the following guidelines:

(a) Provide an automatic emergency 100 percent exhaust system, in the gantry room, to remove helium gas during an accidental spill. The minimum capacity of the exhaust system shall be 12 air changes per hour or 33.6 Cu M/Min (1200 CFM). The gas shall be discharged at the highest point in the building. The oxygen sensors shall activate the exhaust system when the level of oxygen drops below a predetermined level. It is usually 18 percent.

(b) Provide separate vents to remove helium gas produced during boil-off and quench of the magnet. While the boil-off is a normal venting phenomenon, the quench occurs when a super conductive magnet becomes resistive. Coordinate sizes of HVAC equipment, including pressure drops with the magnet manufacturer. Helium liquid turns into gas and tends to occupy enormously high volume.

(c) The air distribution ductwork shall be constructed of either PVC or aluminum to maintain the integrity of the magnetic field.

3.17.2.2 COMPUTER COOLING UNITS: This unit is required for the High-field system only. The specific requirements are:

(a) The air supply outlets shall be located at the floor level with the air directed toward the cabinet inlets. The return air inlets shall be located at the ceiling level, above the cabinets, and near equipment exhaust.

(b) The physical location of the cooling unit should be coordinated with the magnetic field line and should be away from the 10 gauss (unit for magnetic field intensity) line.

(c) The supply air entering the computer room shall be at 18 degrees C (65 degrees F) dry-bulb temperature and 60 percent RH maximum.

3.17.2.3 MRI COOLING UNITS: To cool the MRI and control equipment, a dedicated, closed-loop water-cooling equipment shall be provided. The equipment shall comprise of a dedicated air-cooled, chiller, circulating pump and interconnecting piping. See [Paragraph 2.12.9](#) for the dedicated refrigeration unit. Other specific requirements are:

(a) The pH level, total solid content, total hardness, and alkalinity of the circulating water shall be within the limits prescribed by the equipment manufacturer.

(b) The limits of the inlet water temperature, pressure drop through the equipment, and maximum inlet water pressure shall be in accordance with the equipment manufacturer's recommendations.

(c) The water piping design shall meet the "Radio Frequency" requirements. The piping laid in walls and chases shall be provided with clearly marked and identified access doors for servicing valves and other piping specialties.

(d) While the environmental and computer air handling units shall be connected to the building central chilled water system, for back-up, the capacity of the dedicated air-cooled water chiller shall also include the cooling loads of the environmental air handling unit and computer room cooling unit. The selection of the leaving chilled water temperature shall, therefore, be such that the requirements of entering water temperature to the water cooled equipment and the supply air temperatures of the air cooling units are simultaneously satisfied.

3.17.2.4 ALARMS:

(a) Ambient Temperature Alarm: Provide a high temperature alarm local and at the ECC, if available, for the temperature sensor. The sensor is to be located near the top rear of the computer cabinets. The sensor will be supplied by the MRI equipment manufacturer.

(b) Water Alarm: Provide water sensor alarms (local and the ECC, if available) on the raised deck and under the raised flooring. It shall close and sound the alarm upon detection of moisture water supply to the equipment.

3.17.2.5 GAS STORAGE: The storage rooms, housing helium and nitrogen cylinders, shall be ventilated in accordance with the criteria outlined in Article 4.5, Flammable and Combustible Liquid Storage Spaces.

3.18 PSYCHIATRIC AREAS

3.18.1 INDOOR DESIGN CONDITIONS

Summer: 24 degrees C (76 degrees F) Db, 50 percent RH

Winter: 25 degrees C (78 degrees F) Db, 30 percent RH

3.18.2 SUPPLY AIR

Maintain a minimum of 4 air changes per hour in Patient Rooms.

3.18.3 SPECIAL CONSIDERATIONS

The considerations listed below may be applicable to the complete psychiatric areas or only a few designated seclusion rooms. Coordinate details with the VA.

(a) Avoid the use of exposed and accessible HVAC equipment in patient areas. Examples: floor mounted fan coil units, radiators, convectors, and finned tube radiation, etc.

(b) Exposed piping shall not be used.

(c) Use an aspirating thermostat or a duct mounted temperature sensor programmable from a remote control panel. Seclusion rooms shall be provided with individual temperature controls.

(d) If the radiant ceiling panels system is used:

(1) Maintain the ceiling height as high as possible.

(2) Do not use conventional lay-in tile ceiling construction. Use concealed snap in arrangement.

(3) Use security clips to retain ceiling panels in place against possible damage by patients.

(e) Wall-mounted or security type ceiling-mounted diffusers, grilles and registers are preferred in psychiatric wards. Coordinate the selection of grilles, registers, and diffusers with the medical center.

3.18.4 EXCEPTION

The above requirements are not applicable to long-term geriatric patients who are not prone to violent temperamental behavior.

3.19 SHIELDED ROOMS

3.19.1 GENERAL

Coordinate locations of the shielded rooms with the architectural floor plans.

3.19.2 LEADED SHIELDED DUCT REQUIREMENTS

(a) Ducts penetrating lead-lined walls should be wrapped with lead sheet of the same thickness as the wall lining. The lead shielded duct passing

through the wall should have a double offset in the form of a Z. The offset in the Z should be at least 200 mm (8 inches) long.

(b) In a super voltage, or similar room, with thick concrete shield, lead shielding is not required for ducts penetrating the room wall beyond the shield inside the room.

(c) Dark rooms require a full height lead lining. However, the wall adjacent to Radiographic or similar rooms the normal lead lining is only 2 m (7 ft) high. Ducts penetrating this wall above the suspended ceiling may not need lead shielding.

3.20 SPD (SUPPLY, PROCESSING AND DISTRIBUTION)

3.20.1 GENERAL

3.20.1.1 See [paragraph 2.11.5](#) for the special exhaust requirements for the ethylene oxide sterilizer (ETO) and associated items.

3.20.1.2 Provide a dedicated, 100 percent outdoor air, constant volume air-handling unit to serve the SPD suite.

3.20.2 INDOOR DESIGN CONDITIONS

Summer: 24 degrees C (76 degrees F) Db, 50 percent RH

Winter: 22 degrees C (72 degrees F) Db, 30 percent RH

3.20.3 SUPPLY AIR AND ROOM PRESURE

See Table 3-4.

Table 3-4 Minimum Supply Air and Room Pressure Requirements

Area	Minimum Supply Air Changes Per Hour	Room Pressure
Administrative Office	4	0
Corridors	4	0
Lounge	6	0
Soiled Decontamination Area	10	Negative
Clean Preparation Area	10	Positive
Lockers, Toilets and Shower	10	Negative
ETO Sterilizer/Aerator Room	10	Negative
Equipment Wash Area	10	Negative
Equipment Room	10	0
Equipment Storage and Testing Room	4	0
ETO Sterilizer Room	10	Negative
General Storage Room	4	0

3.20.4 EMERGENCY POWER REQUIREMENTS

ETO exhaust systems shall be on emergency power.

3.20.5 REFERENCE DOCUMENT

See Design Guide "Supply, Processing and Distribution" for requirements in individual rooms.

3.20.6 ETO EXHAUST SYSTEM

3.20.6.1 GENERAL: A dedicated exhaust system shall be provided to exhaust the following area:

- (a) ETO Sterilizer Door Area
- (b) ETO Aerator
- (c) Mechanical Space Housing ETO Sterilizer(s)
- (d) Storage Space Housing ETO Cylinders
- (e) ETO Sterilizer Vacuum Pump Discharge Floor Drain
- (f) ETO Relief Valve Discharge Pipe
- (g) Mechanical Chase housing ETO Cylinders

3.20.6.2 The exhaust system shall operate 24 Hours/Day and maintain negative pressure in the areas housing ETO equipment even when the supply air unit shuts down during unoccupied hours.

3.20.6.3 SPECIFIC DESIGN FEATURES:

- (a) The discharge air from the exhaust fan shall be released at the highest point above the building and care shall be taken to ensure that the discharge air does not short circuit and find its way into the intake of any air handling unit.
- (b) The specific exhaust air intake locations listed in [paragraph 3.20.6.1](#) above have unique, but widely differing requirements of the static pressure drops at the inlet. Coordinate this information with the equipment manufacturer and provide air flow control valves in branch ducts, as required, to balance the system.
- (c) Provide an airflow measuring device in the main exhaust duct, on the intake side of the exhaust fan at an accessible location. Provide a local alarm in the event the airflow monitored at the measuring device drops by 15 percent or if the fan stops completely. If the scope of work includes a central DDC/ECC system, the capabilities shall be provided to monitor the exhaust system, together with remote start-stop and alarms by providing appropriate Analog and Binary signals.
- (d) Do not provide any heat recovery device in the ETO exhaust system.
- (e) The exhaust ductwork shall be continuously welded.

3.20.7 SPECIAL SPD EXHAUST SYSTEM

Provide dedicated exhaust systems for cart and cage washers to handle saturated wet exhaust air. The ductwork and fan shall be constructed from corrosion resistant materials. Provide alternate motorized exhaust air connections to direct air to the general exhaust system when the washers and their respective exhaust systems are not in operation.

3.20.8 GENERAL SPD EXHAUST SYSTEM

Provide a dedicated general exhaust system for the entire SPD suite, including steam sterilizers. Note the following guidelines:

3.20.8.1 An air-to-air or glycol run around heat recovery system can be installed in the exhaust system.

3.20.8.2. Provide appropriate air balance to maintain:

- (a) Positive pressure in clean and preparation area
- (b) Negative pressure in soiled and dirty area
- (c) Negative pressure in entire SPD area
- (d) Limiting maximum air temperature in the mechanical chase housing the steam sterilizers

3.21 SURGERY SUITE SYSTEMS

3.21.1 GENERAL

Each Operating Room (O.R.) in the surgery suite shall have an individual temperature and humidity control. Cystoscopy Room shall be treated as an Operating Room if the room is a part of the surgery suite. For location other than surgery suite, such as, the Spinal Cord Injury Unit, the Cystoscopy Room shall be treated as a special procedure room only.

3.21.2 INDOOR DESIGN CONDITIONS

Summer and Winter: Adjustable 17-27 degrees C (62-80 degrees F) and 45-55 degrees RH.

3.21.3 SUPPLY AIR

Maintain minimum of 15 air changes per hour, when the operating room is occupied and 8 air changes per hour when the room is unoccupied, with at least 100 percent outdoor air.

3.21.4 EMERGENCY POWER REQUIREMENTS

All supply and exhaust fans, dedicated chillers and pumps and controls servicing surgical suites shall be on emergency power.

3.21.5 SYSTEM DESCRIPTION

Provide dedicated supply and exhaust air systems for the Surgery Suite. . The supply air system shall be single duct, low velocity type with unlined constant volume reheat terminal units. The supply air terminal units serving O.R. shall have two-position settings (occupied and unoccupied) manually controlled by a switch located in each O.R. and/or at the associated nursing unit. The exhaust duct shall also be equipped with corresponding two-position, tracking air flow control valves to maintain pressure relationship during occupied and unoccupied modes.

3.21.6 AIR HANDLING UNITS (AHUs)

The AHUs serving Surgery Suite shall have pre-filters, after-filters (except orthopedic surgery units, which shall also have a terminal HEPA filter), energy recovery coil, cooling coil, central humidifier (to raise humidity level up to 30 percent RH), and a variable speed fan for the air volume control. The after-filters shall be located on the discharge side of the fan with a diffuser section in between, to ensure uniform

distribution of airflow over the filter surface. See [Article 2.3](#) for access sections requirements.

3.21.7 AIR DISTRIBUTION

The supply air duct on the downstream side of the after-filters shall be stainless steel with airtight access panels at each elbow and at 6 m (20 feet) interval on straight duct runs for cleaning and inspection. The air distribution for each O.R. shall have stainless steel multiple slot panel diffusers positioned around the operating tables to discharge 70% supply air in a vertical air stream inclined at a 15 degrees outward angle. The remaining 30 percent supply air shall be delivered downward over operating area using perforated face outlets. Provide a minimum of two exhaust registers in each O.R., located diagonally opposite seven inches above the finished floor. The exhaust air quantity shall be at least 15 percent less than the supply air to maintain positive pressure between the O.R. and the adjoining areas.

3.21.8 MISCELLANEOUS

3.21.8.1 The individual humidity for each O.R. shall be maintained by a terminal humidifier on the downstream side of the dedicated constant volume reheat air terminal unit serving the space.

3.21.8.2 Each O.R. shall be furnished with temperature and humidity recorders to keep a continuous record. In lieu of the chart records, temperature and humidity sensors can be used to record data at the Engineering Control Center.

3.21.8.3 See [Article 2.12](#) for the dedicated chilled water system for the Surgery Suites and [Article 2.16](#) for the emergency power requirements.

3.21.8.4 See [Article 2.3.4](#) for restrictions on lining of Terminal Units for the Operating Rooms.

3.22 TB CRITERIA

(FOR SUSPECTED OR KNOWN INFECTIOUS TB (S/KI TB) PATIENT ROOMS AND RELATED AREAS AND CLINICAL MYCOBACTERIAL LABORATORIES).

3.22.1 GENERAL

(a) The health care authorities at the medical center and/or the health care planners shall be responsible for classifying the specific medical center as a high or low incidence area and shall be responsible for determining the location, and quantity of specialized rooms which would be established for S/KI TB patients.

(b) The health care authorities at the medical center and/or the health care planners and Pathology shall be responsible for identifying BSL3 Clinical Mycobacterial Laboratories requiring special architectural and engineering controls in accordance with BSL3 biosafety guidelines recommended by Center for Disease Control (CDC) and National Institutes of Health (NIH).

3.22.2 REFERENCE DOCUMENTS

(a) Center for Disease Control (CDC): "Guidelines for Preventing the Transmission of Mycobacterium Tuberculosis in Health-Care Facilities, 1994", MMWR Morbidity and Mortality Weekly Report, published by U.S. Department of Health and Human Services-Public Health Service.

(b) Program and Facility Planning for Tuberculosis Programs, August 18, 1995.

(c) CDC/NIH Publication "Biosafety in Microbiological and Biomedical Laboratories", 3rd Edition, May 1993.

3.22.3 POLICY AND PROCEDURES

(a) Where the VA Design Criteria exceed the minimum requirements outlined in the CDC document, compliance with the VA Criteria is mandatory for all new facilities and major renovation projects. For existing facilities where compliance with the VA Criteria may not be feasible (or cost effective) due to the limitations of the configuration of the HVAC system, the minimum requirements outlined in the CDC document shall suffice.

3.22.4 BASIC DESIGN PARAMETERS

3.22.4.1 Indoor design conditions in TB rooms and associated areas are listed in Table 3-5.

Table 3-5 TB Criteria Indoor Design Conditions

ROOM OR AREA	SUMMER		WINTER	
	Db Degrees C (Degrees F)	RH (Percent)	Db Degrees C (Degrees F)	RH (Percent)
Ante Rooms	25 (78)	50	22 (72)	30
Isolation Rooms for s/KI TB patients	24 (76)	50	25 (78)	30
Bathrooms & Toilets	25 (78)	---	22 (72)	---
Treatment Areas	24 (76)	50	25 (78)	30
Intensive Care Unit AFB (Acid Fast Bacilli)	22 (72)	50	25 (78)	30
TB Dental Operatory	24 (76)	50	25 (78)	30
TB Dialysis Room	24 (76)	50	25 (78)	30
Ambulatory Care Areas including Emergency Care and Waiting areas	24 (76)	50	25 (78)	30
Clinical Mycobacterial BSL3 Laboratories	24 (76)	50	22 (72)	30

Notes:

(1) These are design conditions and not operating limits. All thermostats shall be adjustable between 16 to 29 degrees C (60 to 85 degrees F) range.

(2) The summer indoor design relative humidity shown above need not be maintained by any humidity control, either at the air terminal units or at the air handling units. These values merely represent design reference points and, in actual practice, would vary due to the predetermined air quantities and fluctuations in the internal heat loads. The winter indoor design relative humidity shall be maintained by a humidifier either at the air terminal unit or at the air handling unit, or both.

(3) Depending upon the weather conditions, winter humidification may be deleted from the air-handling unit serving non-patient areas. The decision to do so, however, shall be reviewed with and approved by the VA.

(4) Bathrooms and toilets do not require individual room temperature control in the cooling mode. Provide a terminal heating device and space temperature control in heating mode for exterior bathrooms/toilets.

(5) The following areas are designated as "TB Treatment Rooms" for the purpose of this criteria. They typically are spaces where procedures are performed and/or treatments are administered to the S/KI TB patients.

(a) Diagnostic Sputum Induction.

(b) Administration of Aerosolized Pentamidine (AP) Drug. This also includes other aerosol treatments, cough-inducing procedures, or aerosol-generating procedures.

(c) Bronchoscopy.

3.22.4.2 See Table 3-6 for supply air requirements:

Table 3-6 TB Criteria Supply Air Requirements

ROOM OR AREA	MINIMUM AIR CHANGES PER HOUR
Ante Rooms (recommended but not required for AFB Isolation Rooms)	12
Emergency Care Areas	12
Treatment Rooms	12
ICU AFB Isolation Rooms*	12
TB Dental Operatory	12
TB Dialysis Rooms	12
Isolation Rooms for treatment of S/KI TB patients	12
TB Radiology Rooms (One Required)	12
Clinical Mycobacterial Laboratories	12

* Air changes/hour should include at least two outdoor air changes per hour.

NOTES:

(1) Outdoor air requirements do not need to be provided directly to room. They are normally provided at the air-handling unit.

(2) If the room air is recirculated in ambulatory care areas, a minimum of 2 air changes per hour of outdoor air will be required.

(3) The supply air changes shall be increased as required to meet the demands of the cooling load.

(4) The minimum supply air for the anterooms shall not be less than 1.7 Cu M/Min (60 CFM).

(5) For corridors in the immediate vicinity of the S/KI TB Isolation Rooms and TB treatment rooms, sufficient ducted supply air shall be provided to serve as a make-up air necessary to maintain negative pressure in TB patient rooms. Consequently, no exhaust or return air registers should be located in the corridors. The use of the corridor air as a make-up air for the toilets and other areas, adjoining to the corridors, is described in the following paragraph.

3.22.4.3 EXHAUST AIR SYSTEMS

(a) Following areas require 100 percent exhaust. The air supplied to these areas shall be exhausted outdoors through a dedicated exhaust system.

- (1) Ante rooms
- (2) S/KI TB Isolation Rooms
- (3) TB Treatment Rooms
- (4) TB Dental Operatory
- (5) TB Dialysis Room
- (6) TB Radiology Room
- (7) Clinical Mycobacterial BSL3 Laboratories

(b) In addition, all toilets, bathrooms, janitor closets, and locker rooms, associated with S/KI TB Isolation Rooms or treatment rooms, shall also be exhausted outdoors.

3.22.4.4 Return Air Systems

(a) Following areas can utilize return air systems in lieu of 100 percent outdoor air system. A life cycle cost analysis shall be made to determine the most cost effective system.

- (1) Unscheduled Ambulatory Care Areas, Emergency Care Areas, and associated Waiting Areas
- (2) Scheduled Ambulatory Care Areas

(b) Air supplied to the ambulatory care area can be recirculated and returned back to the air handling unit provided the return air is recirculated through high efficiency particulate air (HEPA) filters.

(c) HEPA filters shall be installed at the air-handling unit only. HEPA filters installed in branch return air ducts will create air-balancing problems.

(d) Germicidal UV Irradiation: The use of UV lamps in the return air ducts is optional. It is not a requirement by CDC. The effectiveness of UV lights is discussed in the CDC document. It is important that staff and patients are protected from possible injury from the UV irradiation, and the equipment be properly maintained.

3.22.4.5 AIR PRESSURIZATION: The following areas shall be maintained under negative pressure of at least 0.025 mm (0.001 inch) of water by exhausting 10 percent more air than the air supplied to them.

(a) Anterooms

(b) AFB Isolation Rooms

(c) Treatment Rooms

(d) TB Radiology Room

(e) TB Dental Operatory

(f) TB Dialysis Room

(g) Clinical Mycobacterial BSL3 Laboratories

(h) Note the following:

(1) The use of the anteroom is not mandatory for S/KI TB isolation rooms. However, S/KI TB isolation rooms are often entered frequently and the use of anterooms minimize the potential for droplet nuclei (airborne infectious particles) spreading to the adjoining areas. The need for anterooms should be discussed with the medical center.

(2) It is important to distinguish between the S/KI TB isolation rooms and conventional isolation rooms with required reverse isolation capability. With reverse isolation capability, the direction of air flow and the air pressure and the patient rooms can be changed from positive to negative with a change in the selector switch. S/KI TB Isolation rooms are to remain under negative pressure at all times. S/KI TB patients shall not be treated in a positive pressure environment.

(3) While conventional isolation room exhaust fans are required to be on emergency power, CDC does not require TB isolation room exhaust fans to be on emergency power. Therefore, consult the medical center staff for providing emergency power for exhaust systems serving inpatient TB patient rooms and some of the ambulatory care rooms designated for management of TB patients. The potential risks to relative priority of other functions covered by the emergency power should be carefully evaluated when considering costly emergency power system expansion.

3.22.4.6 AIR DISTRIBUTION: The air distribution system for S/KI TB isolation rooms and TB treatment rooms shall be designed to ensure that the air distribution patterns have the following characteristics:

(a) The supply air flows towards the patient beds or treatment tables and not towards corridors or adjacent areas.

(b) The exhaust air registers are located close to the patient.

(c) CDC requires that the negative pressure in the room should be monitored daily while the room is being used for TB isolation. This could be as simple as periodic measurement of the direction of air flow direction using simple procedures such as flutter strips or small amounts of smoke, or can utilize more elaborate pressure sensors. As a minimum we recommend that the exhaust fan be monitored with an airflow switch such that alarms are sent to a central location, such as the engineering control center (ECC) or nurses station if the fan stops. However the monitoring is accomplished, it should be documented regularly with records maintained for a reasonable length of time. VAMC staff should use their judgment to determine if more elaborate monitoring systems are required for their application.

3.22.5 AIR HANDLING SYSTEMS (EXISTING AND NEW FACILITIES)

3.22.5.1 EXISTING FACILITIES

3.22.5.1.1 All AIR SYSTEMS: The S/KI TB isolation rooms and TB treatment rooms should be located in existing facilities only where "all air" types of HVAC systems are installed, provided these systems operate 24 hours a day including the following:

(a) The existing HVAC systems have adequate spare capacity to meet the increased demand for the supply and outdoor air volumes. Components, such as supply air fan, motor, cooling and heating coils, and the elements of the air distribution system, should be closely reviewed and revised, as necessary, to meet the new duty conditions.

(b) Individual room temperature control is required for each patient room and treatment room. For the ambulatory care areas (emergency rooms and waiting areas etc.), individual room temperature control is desirable, but not mandatory.

3.22.5.1.2 FAN COIL UNITS: The S/KI TB isolation rooms and TB treatment rooms and waiting areas for S/KI TB patients shall not be located in areas utilizing fan coil units because of the following reasons:

(a) Recirculation of room air will make it difficult to control droplet nuclei.

(b) The periodic removal and replacement of air filters, installed in fan coil units, could be an additional source of contamination. These filters are inefficient for preventing the spread of droplet nuclei.

(c) With fan coil units, the quantity of outdoor air is small, estimated only to meet the minimum ventilation and/or toilet exhaust needs. The feasibility and cost of increasing the outdoor air quantity, to meet the

criteria for specified air changes per hour, would restrict the conversion of these spaces for S/KI TB patient treatment.

3.22.5.1.3 RADIANT CEILING PANELS: The areas equipped with radiant ceiling panels in the cooling mode can be retrofitted as S/KI TB isolation rooms and TB treatment rooms. However, the modifications to the existing HVAC system would be costly and technically difficult. See explanation below:

(a) The conditioned minimum ventilation air supplied to the spaces will not be sufficient to meet the air changes per hour requirement. The necessary modifications to the air-handling unit and air distribution ductwork would be costly.

(b) The room temperature control sequence will require extensive changes and the technical feasibility is questionable. Typically, a room thermostat controls the space cooling requirements by modulating an automatic flow control valve installed in the chilled water piping serving the radiant ceiling panels. The minimum room ventilation air is cooled and dehumidified to remove the space latent heat gain (in addition to the space sensible heat gain) is uncontrolled at room level. If the ventilation air volume is increased up to the specified air changes per hour, in most instances, it will be able to meet the total cooling needs of the space without any assistance from the radiant ceiling panels. Consequently, to avoid conflict with the radiant ceiling panels, the conditioned ventilation air cannot remain uncontrolled and a suitable room temperature control sequence must be devised so that both cooling sources, radiant panels and ventilation air, are under the control of one room thermostat. Such a sequence will invariably involve reheating of ventilation air resulting in the loss of energy. Besides, should there be any increase in the level of occupancy (e.g. waiting areas, treatment rooms etc.), there is a distinct possibility of condensation of moisture on the panel surface.

3.22.5.2 NEW CONSTRUCTION: For new construction, "all air" systems shall be provided. The system may be dedicated for tuberculosis care if the layout of the areas is such that all related functions can be grouped together on one ward, as it might be in areas of high incidence of the TB. However, often the S/KI TB isolation rooms and TB treatment areas are distributed in the facility. In this case, the areas can be served by the "all air" systems serving the adjoining spaces. In addition to the requirements outlined in Paragraph 3.22.5.1 for all air systems, the dedicated systems shall have the following additional features:

- (1) 100 percent outdoors air for the dedicated air-handling unit.
- (2) Single zone, constant volume reheat (CVRH) system.
- (3) Double wall construction.
- (4) Horizontal or vertical, draw-thru configuration. Blow-thru configuration shall not be used.
- (5) The unit shall be equipped with 30 percent ASHRAE test efficiency pre-filters and 90 percent ASHRAE test efficiency after-filters. Utilize HEPA filters for areas, where required above, in lieu of 90 percent after-filters.

(5) The use of HEPA filters in the 100 percent exhaust from the TB isolation suite is not necessary, but its use should be considered whenever exhaust air could possibly reenter the system.

(6) Whenever the project requires winter humidification and perimeter heating, they shall be included in the system design. Note that the winter humidity control is not required on a room-by-room basis but only at the air handling unit level. The perimeter heating control shall be integrated with the room temperature control so that only the room thermostat controls the air reheat and the perimeter heat in sequence.

3.22.5.3 EXHAUST AND INTAKE OUTLETS: Air exhausted to the outdoor as a method of reducing the risk of transmission of tuberculosis should be exhausted in a manner and at a location so as not to be pulled into air intake louvers. As a minimum, the exhaust air discharge shall be 30 feet from any air intake. However, other factors, such as wind direction, wind velocity, stack effect, system sizes and height of building, must be evaluated in the location of air intakes and exhaust outlets. Refer to Chapter "Air Flow Around Buildings" of ASHRAE Fundamentals Handbook for analyzing these factors.

Blank page left intentionally

CHAPTER 4: HVAC REQUIREMENTS FOR UNOCCUPIED AREAS

- 4.1 BATTERY CHARGING AREAS
 - 4.1.1 GENERAL
 - 4.1.2 EXHAUST AIR REQUIREMENTS
 - 4.1.3 EMERGENCY GENERATORS/SWITCHGEAR ROOM GENERATORS
 - 4.1.4 WHEELCHAIR BATTERY CHARGING AREA
- 4.2 BIOMEDICAL INSTRUMENT REPAIR SHOP
 - 4.2.1 GENERAL
 - 4.2.2 EXHAUST AIR REQUIREMENTS
- 4.3 ELEVATOR MACHINE ROOMS
- 4.4 EMERGENCY GENERATOR ROOMS
- 4.5 FLAMMABLE AND COMBUSTIBLE LIQUID STORAGE SPACES
 - 4.5.1 GENERAL
 - 4.5.2 HVAC REQUIREMENTS
- 4.6 REAGENT GRADE WATER TREATMENT ROOMS
 - 4.6.1 GENERAL
 - 4.6.2 EXHAUST AIR SYSTEM
- 4.7 RADIOACTIVE IODINE
 - 4.7.1 GENERAL
 - 4.7.2 MAXIMUM CONCENTRATION
 - 4.7.3 EXHAUST AIR SYSTEM
 - 4.7.4 EMERGENCY POWER REQUIREMENTS
- 4.8 TELEPHONE EQUIPMENT ROOMS
 - 4.8.1 GENERAL
 - 4.8.2 INDOOR DESIGN SYSTEM
 - 4.8.3 EMERGENCY POWER REQUIREMENTS
 - 4.8.4 HVAC REQUIREMENTS
- 4.9 TRANSFORMER ROOMS (VAULTS) AND ELECTRIC CLOSETS
- 4.10 TRASH COLLECTION AREAS
- 4.11 WALK-IN REFRIGERATORS
 - 4.11.1 GENERAL
 - 4.11.2 DESIGN PARAMETERS
 - 4.11.3 FROST FORMATION AND FLOOR HEAVAGE PREVENTION
 - 4.11.4 REFRIGERATOR AND FREEZER APPLICATIONS
- 4.12 XENON GAS
 - 4.12.1 GENERAL
 - 4.12.2 DESIGN CONSIDERATIONS

Blank page left intentionally

4 HVAC REQUIREMENTS FOR UNOCCUPIED AREAS

4.1 BATTERY CHARGING AREAS

4.1.1 GENERAL

The exhaust ventilation system for the battery charging areas depends upon the type of batteries used.

4.1.2 AUTOMATIC TRANSPORT SYSTEMS (ATS)

The lead-acid batteries, used for the ATS, require a dedicated exhaust system to remove fumes from the area and prevent build-up of explosive mixtures from the batteries.

4.1.2 EXHAUST AIR REQUIREMENTS

- (a) Maintain a minimum of 8 air changes per hour and negative pressure in the battery charging air.
- (b) The exhaust system shall be corrosion-resistant stainless steel ductwork, spark-proof construction fan, and explosion proof motor.
- (c) The wall or ceiling mounted exhaust registers shall be located over the batteries to capture the fumes directly.
- (d) Exhaust fan shall be on emergency power.
- (e) Air flow switch shall be provided to detect interruption in airflow with audible and visible alarms, local as well as at the Engineering Control Center.

4.1.3 EMERGENCY GENERATOR/SWITCHGEAR ROOM BATTERIES

The batteries used in these areas are Ni-Cad type, which do not generate fumes. There are no special exhaust requirements for these batteries. See [paragraphs 2.10.6 and 2.10.7](#) for ventilation requirements of the emergency generator room and switchgear rooms.

4.1.4 WHEEL CHAIR BATTERY CHARGING AREA

Provide ventilation system in accordance with [paragraph 4.1.2](#) if the area has capacity to charge 5 wheel chairs concurrently.

4.2 BIOMEDICAL INSTRUMENT REPAIR SHOP

4.2.1 GENERAL

Provide air conditioning for the space from a central air conditioning unit serving adjoining engineering shops.

4.2.2 EXHAUST AIR REQUIREMENTS

Provide a dedicated exhaust system. The canopy type stainless steel exhaust hood (Type A, B, or C) located in the repair section of the shop shall exhaust room air at the rate of 0.51 m/s (100 fpm) over the hood area. Coordinate hood location and size with the architectural equipment drawings. Since the repair work involves use of mercury, xylene, and other toxic chemicals, the exhaust system shall be of corrosion resistant ductwork, spark-proof fan, and explosion proof motor. Provide an alternate return air duct with motorized dampers to

return room air back to the air-handling unit when the hood is not in operation.

4.3 ELEVATOR MACHINE ROOMS

See [Article 2.10.5](#)

4.4 EMERGENCY GENERATOR ROOMS

See [Article 2.10.6](#)

4.5 FLAMMABLE AND COMBUSTIBLE LIQUID STORAGE SPACES

4.5.1 GENERAL

The mechanical ventilation system shall be designed in accordance with NFPA-30.

4.5.2 HVAC REQUIREMENTS

(a) Each flammable and combustible liquids storage space shall have its own dedicated exhaust system. The exhaust fan shall discharge at a safe distance above the highest point of the building to prevent recirculation.

(b) Exhaust air at the rate of 0.27 Cu M/Sq M (1.0 CFM/Sq. Ft) with a minimum of 4.5 Cu M/Min (150 CFM).

(c) Exhaust fan shall be on emergency power.

(d) Locate the exhaust and make-up air inlets 300 mm (12 inches) above the finished floor on the opposite side of room to avoid short-circuiting of air.

(e) Provide an explosion proof motor and spark-proof fan. The fan bearings should not come in contact with the exhaust air stream.

(f) Provide an airflow switch to detect interruption in airflow with audible and visible alarms, local as well as at the Engineering Central Center.

4.6 REAGENT GRADE WATER TREATMENT ROOMS

4.6.1 GENERAL

These rooms, generally located near Supply-Processing and Distribution (SPD) or Laboratories, contain equipment that produces de-ionized water. The room should be well ventilated because of corrosive chemicals used in the process to produce deionized water.

4.6.2 EXHAUST AIR SYSTEMS

The exhaust system shall have the following specific features:

(a) Maintain a minimum of exhaust at the rate of 8 air changes per hour.

(b) Exhaust fan shall be on emergency power.

(c) The exhaust systems shall have corrosion-resistant all welded stainless steel ductwork spark-proof construction fans and explosion proof motors.

(d) The exhaust systems shall run continuously. Airflow switch shall provide an interruption in airflow with audible and visible alarms located locally as well as at the Engineering Control Center.

4.7 RADIOACTIVE IODINE

4.7.1 GENERAL

The procedure, to calculate the amount of exhaust air quantity to dilute the concentration of radioactive iodine material, is similar to the Xenon gas. See [Article 4.12](#) for details.

4.7.2 MAXIMUM CONCENTRATION

The Maximum Permissible Concentration (MPC) of the radioactive iodine in the exhaust air discharged into unrestricted areas, averaged over a period of one year, shall not exceed:

(a) Iodine 131: 1×10^{-10} Micro-Curies Per Milliliter of Volume

(b) Iodine 125: 8×10^{-11} Micro-Curies Per Milliliter of Volume as outlined in the Code of Federal Regulations (CFR), Part 20, Appendix "B", Table II of the Nuclear Regulatory Commission.

4.7.3 EXHAUST AIR SYSTEM

Provide a dedicated exhaust system to dilute and dispose radioactive iodine material. Establish the amount of activity used in the space from the medical center personnel and calculate the exhaust air quantity by using the equations outlined in [Article 4.12](#). The calculations should be reviewed and approved by the VA Radiation Safety Officer. The exhaust air should be discharged at the highest point above the building. The exhaust air shall be picked up either through the space or a H3 hood.

4.7.4 EMERGENCY POWER REQUIREMENTS

The exhaust system shall be on emergency power.

4.8 TELEPHONE EQUIPMENT ROOMS

4.8.1 GENERAL

Assume sensible heat gain to the space at the rate of 1350 W (4,500 BTUH) per 100 lines of telephone service. Estimate the cooling requirements on the basis of the present plus future capacity of the telephone service. Coordinate this information with Telecommunications Support Service of the VA at the Headquarters.

4.8.2 INDOOR DESIGN CONDITIONS

Summer and Winter: 19 to 23 degrees C (65 to 75 degrees F), 40 to 60 percent RH

4.8.3 EMERGENCY POWER REQUIREMENTS

HVAC equipment serving telephone equipment rooms shall be on emergency power.

4.8.4 HVAC REQUIREMENTS

Wherever possible, use the building environmental air-handling unit, as the primary source, to serve the Telephone Equipment Room. Provide individual room temperature control. In addition, provide a 100 percent

back-up air handling/cooling system for the telephone room when the building environmental and cooling systems are inoperative. The backup cooling system shall either be an air-cooled DX or an air-cooled chilled water type with air handling unit and controls. See [paragraph 2.12.9](#) for the dedicated refrigeration system. Consider the use of a portable room humidifier if the steam humidification is not feasible. Any pipe or duct system foreign to the telephone equipment installation shall not pass through a telephone equipment room or a closet.

4.9 TRANSFORMER ROOMS (VAULTS) AND ELECTRIC CLOSETS

See [paragraph 2.10.7](#) for ventilation requirements.

4.10 TRASH COLLECTION AREAS

See [paragraph 2.10.4](#) for ventilation requirements.

4.11 WALK-IN REFRIGERATORS

4.11.1 GENERAL

See VA Master Specifications and Standard Details. Controlled Temperature Rooms in laboratories or research are part of the equipment purchased either directly by the VA or the Contractor, but not by the mechanical contractor. Provide audible and visual temperature alarms locally and at the ECC.

4.11.2 DESIGN PARAMETERS

Load calculations, heat gain factors, compressor running time, etc., shall be in accordance with ASHRAE Guide and Data books. Design temperature shall be as follows:

Table 4-1 Design Temperatures, Degrees C (Degrees F), Walk-in Refrigerators/Freezers

Refrigerator/Freezer Type	Temperatures Degrees C (Degrees F)
Dairy Freezers	-29 (-20)
Ice Cream Freezers	-29 (-20)
Meat Freezers	-24 (-12)
Fresh Meat Refrigerators	0 (32)
Walk-in Refrigerators	2 (36)
Autopsy (Mortuary) Cold Rooms	2 (36)
Subsistence Storages (Supply Service)	2 (36)

4.11.3 FROST FORMATION AND FLOOR HEAVAGE PREVENTION

All freezers and meat refrigerators, on grade or above grade with fill, shall have provisions to prevent frost formation and subsequent floor heavage. The usual method is to provide heating cable (type M1 which shall be shown on the electrical drawings) in the concrete sub-floor to keep the ground from freezing. To conserve energy, some form of waste heat using air or water, should be used in the anti-frost system wherever possible.

4.11.4 REFRIGERATOR AND FREEZER APPLICATIONS

(a) Refrigerator and freezer refrigeration motors and controls shall be on the emergency power system. Refer to HVAC Standard Detail 15900-5.

(b) For dietetic units product load is low because the product is usually received infrequently, weekly or even monthly, and its temperature is the same as the storage temperature. Lights are kept off, except when a worker is inside the refrigerator or freezer, but the unit coolers run continuously (except for defrost cycle for freezer units).

(c) See [paragraph 2.11.4](#) for the autopsy cold room ventilation.

(d) Unit coolers for freezers shall be equipped with electric defrost and heated drain pan. All drains shall run through the wall or floor, trapped outdoors, and discharge to an open site sanitary drain.

(e) Where multiple walk-in freezers are involved, consider providing a central water-cooling system, possibly a closed circuit cooling tower with a glycol-water loop to remove the heat. If not, water-cooled condensing units with water regulating valves shall be used. Where a condensing unit is located in a closet size room, mount the condensing unit on the rack approximately four feet high to make the unit accessible. Double tier racks may be provided for multiple condensing units.

(f) If fan room or other mechanical space cannot be conveniently close for locating compressor(s), a well-ventilated compressor room shall be provided near the walk-in refrigerator/freezer. Units or mechanical rooms shall not be located in interstitial space.

4.12 XENON GAS

4.12.1 GENERAL

The restricted areas of the Nuclear Medicine Department, namely, Imaging Room (Patient Examination Room) and Storage & Preparation Area (also known as Radiopharmacy Laboratory or Hot Laboratory) use Xenon Gas (Xe - 133). Xenon Gas, being a radioactive material, requires special ventilation considerations in accordance with the Nuclear Regulatory Commission (NRC), publication 'Guide for Preparation of Applications for Medical Use Program', Guide 10.8, Appendix 0 dated August, 1987 - Revision 2.

4.12.2 DESIGN CONSIDERATIONS

(a) The Imaging Room and Storage & Preparation Area should be kept under negative pressure by exhausting at least 15 percent more air than the supply air. The recirculation of air is not permitted from these spaces.

(b) The Storage & Preparation Area is generally equipped with a radioisotope fume type H3 hood. The exhaust requirements for H3 hood are outlined in [Article 2.11](#).

(c) The use of the Xenon gas depends upon the number of patients examined per 40 hours-week. This number can range from one to fifteen

patients per week and must be determined from the medical center prior to the system design.

(d) Exhaust fan shall be on emergency power.

(e) Exhaust registers shall be located at floor and ceiling level.

4.12.3 VENTILATION CALCULATIONS

For restricted areas (Imaging Room and Hot Laboratory) the supply air quantities, calculated on the basis of the room heat gains due to occupancy, lights, equipment, and fenestration, should be matched with the exhaust air quantities required to dilute the xenon gas concentration.

4.12.3.1 Imaging Room

(a) Exhaust Air Quantity Calculations: The exhaust air quantity discharged into the unrestricted area is calculated on the basis of the following:

$$A \times f = MPC \times V \times T \times 60$$

A = Dose of Xenon Gas Used Per Week

= Number of Patients Per Week x Dose Per Patient

The average dose per patient, according to the DVA Nuclear Medicine Department, St. Louis, MO, is 20,000 micro-curies. Micro-curie is a unit of activity.

f = Fraction of the total dose lost to the patient examination room. It is estimated that 20 percent of the total activity used per week is lost. Use $f = 0.2$.

MPC = Maximum Permissible Concentration 3×10^{-7} micro-curies per milliliter of the space volume for unrestricted area per NRC's recommendation.

V = Exhaust Air Volume Milliliter Per Minute

T = Time in Hours Per Week. Unless stated otherwise, use 40 hours per week.

60 = Minutes Per Hour

V = Air flow - CFM

$$V = \frac{A \times F \text{ CFM}}{MPC \times T \times 60 \times 2.832 \times 10^4}$$

1 Cubic Feet = 2.832×10^4 Milliliters

(b) Spill Clearance Time: The above exhaust air volume should be used as the basis to determine the amount of time, in minutes, required to clear an accidental gas spill. While there is no maximum or minimum time limit prescribed by the NRC, the DVA Nuclear Medicine Department believes the spill should be cleared within 15 to 20 minutes. The spill clearance time is calculated by the following equation:

t = Spill Clearance Time in Minutes

V = Volume of Imaging Room in Milliliters

A = Maximum Activity Accidentally Released; Assumed As Dose Per Patient. 20,000 Micro-curies

Q = Exhaust Air Volume in Milliliters Per Minute

MPC = 1×10^{-5} Micro-curies Per Milliliter Space Volume, per NRC's recommendation for restricted spaces

4.12.3.2 Storage & Preparation Room: Using the Imaging Room spill time, calculate the volume of exhaust air quantity required for the Radiopharmacy Laboratory. The formula is:

$$Q = \frac{(-V)}{t} \times \ln \left(\frac{\text{MPC} \times V}{A} \right)$$

Q = Exhaust Air Quantity in Milliliters Per Minute

V = Volume in Milliliters of Storage & Preparation Room

T = Spill Clearance Time For Imaging Room in Minutes

MPC = Maximum Permissible Concentration 1×10^{-5} Micro-curies Per Milliliter of Space Volume

A = Assumed Spill Per Incident
= Dose Per Patient
= 20,000 Micro-curies

The air quantity, thus calculated should be increased, if required, to meet the needs of the fume hood exhaust or the internal heat load.

Blank page left intentionally

CHAPTER 5 SUPPORT DATA

5.1 APPLICATION DESIGN AND
CONSTRUCTION PROCEDURES AND
REFERENCE INDEX

5.1.1 GENERAL

5.2 SCHEDULES OF TABLES FOR CHAPTERS
1 THROUGH 4

5.3 TABLES FOR VIBRATION ISOLATORS
SELECTION GUIDE

5.4 CLIMATIC CONDITIONS FOR VA
MEDICAL CENTERS

Blank page left intentionally

5 SUPPORT DATA

5.1 APPLICABLE DESIGN AND CONSTRUCTION PROCEDURES, AND REFERENCE DOCUMENTS INDEX

5.1.1 GENERAL

The HVAC design manual is to be used in conjunction with referenced material listed below. Information in referenced material is not duplicated in the criteria.

(a) Department of Veterans Affairs Program Guides, Handbooks, Design and Construction Procedures, and Construction Standards:

- (1) PG-18-1, Master Construction Specifications
- (2) PG-18-3, Program Guide
- (3) PG-18-4, Standard Details
- (4) PG-18-6, Equipment Reference Manual
- (5) PG-18-10, Design Manuals
- (6) PG-18-12, VA Design Guides (several under development, use as available)
- (7) PG-18-15, Minimum Requirements for A/E Submission of Schematic, Design Development and Construction Documents including Cost Estimates (Volumes A, B and C):

Volume A: New and Replacement Hospital Projects

Volume B: Major New Facilities, Major Additions and Major Renovations

Volume C: Minor and NRM Projects

(8) Design and Construction Procedures

Topic 1 Codes and Standards

Topic 2 Drawings

Topic 3 VA Hospital Building System

Topic 4 Foundation Drainage

Topic 5 Pipe Basements

Topic 6 Floor Slab Depressions

Topic 7 Piping, Ducts, and Electrical Conduits

Topic 8 Electrical, Signal, and Telephone Closets and Computer Rooms

Topic 9 Energy Centers

- Topic 10 Computer Systems
- Topic 11 Noise Transmission Control
- Topic 12 Future Vertical Expansion
- Topic 13 Service Life and Replacement Costs
- Topic 14 Security
- Topic 15 Energy Efficient and Sustainable Design Policy for VA New Construction
- Topic 16 Sustainable Buildings Policy for New and VA Renovation Construction
- Topic 17 Physical Security Strategies for New and Renovation VA Construction

(9) Program Guide 7610, Equipment Guide List

(10) H-18-8, Seismic Design Requirements

(11) Natural Disasters Resistive Design (CD-54).

(12) ASHRAE Handbooks (All Volumes), Latest Editions

(13) A/E Alerts

(14) Design Alerts

(15) National Fire Codes - NFPA, Latest Editions

(16) OSHA (Occupational Safety and Health Administration) Regulation 20 CFR Part 10

(17) VA National CAD Standard Application Guide

(18) National CAD Standard

5.2 SCHEDULES OF TABLES FOR CHAPTERS 1-4

Table	1-1	Indoor Design Conditions
Table	1-2	Minimum Supply Air Requirements
Table	1-3	Minimum Outside Air Requirements
Table	1-4	Minimum Exhaust Air Requirements
Table	1-5	Design Noise Criteria
Table	1-6	System/Motor Voltages
Table	1-7	Air Density Correction Factors
Table	1-8	Recommended Building Thermal Envelope for New Construction
Table	1-9	Recommended Over-all "Uo" Factors for New Construction
Table	1-10	Recommended Perimeter Insulation
Table	2-1	Filter Efficiencies (percent) for All-Air Systems
Table	2-2	Heat Transfer Capacity Factors for Glycol Solutions
Table	2-3	Properties of Glycol Solutions
Table	2-4	Ethylene Glycol Solutions; Weight Correction Factors
Table	2-5	Pump Head Correction Factors for Increased Flow
Table	2-6	Pump Head Correction Factors for Increased Viscosity
Table	2-7	Summary Results, Typical Example
Table	2-8	Summary of Correction Factors for Glycol Solutions
Table	2-9	Steam Pressure Classification
Table	2-10	Equipment Steam Pressure Requirements
Table	2-11	Minimum Ventilation Air Changes Per Hour
Table	2-12	Heat Dissipation Data for Elevator Equipment
Table	2-13	H3 Hood Exhaust Air Requirements
Table	2-14	H7/H13 Hood Exhaust Air Requirements
Table	2-15	Direct Connection (Type A and B3 Cabinets) Exhaust Air Requirements
Table	2-16	Indirect Connection (Type A and B3 Cabinets) Exhaust Air Requirements
Table	2-17	H12 Cabinet (Type B1 and B2) Exhaust Air Requirements
Table	2-18	H14 Hood Exhaust Air Requirements
Table	2-19	Chiller Efficiencies for Standard ARI Conditions
Table	3-1	Ventilation Requirements for Laundry
Table	3-2	Medical Media Service Core Areas
Table	3-3	Medical Media Service Expanded Core Areas
Table	3-4	Minimum Supply Air and Room Pressure
Table	3-5	TB Criteria, Indoor Design Conditions
Table	3-6	TB Criteria, Supply Air Requirements
Table	4-1	Design Temperatures, Walk-in Refrigerators/Freezers

5.3 SELECTION GUIDE FOR VIBRATION ISOLATORS

Table 5-1 Selection Guide for Vibration Isolators

EQUIPMENT	ON GRADE			20FT FLOOR SPAN			30FT FLOOR SPAN			40FT FLOOR SPAN			50FT FLOOR SPAN			
	BASE TYPE	ISOL TYPE	MIN DEFL	BASE TYPE	ISOL TYPE	MIN DEFL	BASE TYPE	ISOL TYPE	MIN DEFL	BASE TYPE	ISOL TYPE	MIN DEFL	BASE TYPE	ISOL TYPE	MIN DEFL	
REFRIGERATION MACHINES																
ABSORPTION	---	D	---	---	SP	1.0	---	SP	1.0	---	SP	1.7	---	SP	1.7	
PACKAGED HERMETIC	---	D	---	---	SP	1.0	---	SP	1.7	---	SP	1.7	R	SP	2.5	
OPEN CENTRIFUGAL	B	D	---	B	SP	1.0	---	SP	1.7	B	SP	1.7	B	SP	3.5	
RECIPROCATING:																
500 - 750 RPM	---	D	---	---	SP	1.7	R	SP	1.7	R	SP	2.5	R	SP	3.5	
751 RPM & OVER	---	D	---	---	SP	1.0	---	---	1.7	R	SP	2.5	R	SP	2.5	
COMPRESSORS AND VACUUM PUMPS																
UP THROUGH 1-1/2 HP	---	D,L, W	---	----	D,L, W	---	---	D,L, W	---	---	D,L, W	---	---	D,L, W	---	
2 HP AND OVER:																
500 - 750 RPM	---	D	---	---	S	1.7	---	S	2.5	---	S	2.5	---	S	2.5	
750 RPM & OVER	---	D	---	---	S	1.0	---	S	1.7	---	S	2.5	---	S	2.5	
PUMPS																
CLOSE COUPLED	UP TO 1-1/2 HP	---	---	---	---	D,L, W	---	---	D,L, W	---	---	D,L, W	---	---	D,L, W	---
	2 HP & OVER	---	---	---	I	S	1.0	I	S	1.0	I	S	1.7	I	S	1.7

EQUIPMENT		ON GRADE			20FT FLOOR SPAN			30FT FLOOR SPAN			40FT FLOOR SPAN			50FT FLOOR SPAN		
		BASE TYPE	ISOL TYPE	MIN DEFL	BASE TYPE	ISOL TYPE	MIN DEFL	BASE TYPE	ISOL TYPE	MIN DEFL	BASE TYPE	ISOL TYPE	MIN DEFL	BASE TYPE	ISOL TYPE	MIN DEFL
BASE MOUNTED	UP TO 10 HP	---	---	---	---	D,L, W	---	---	D,L, W	---	---	D,L, W	---	---	D,L, W	---
	15 HP THRU 40 HP	I	S	1.0	I	S	1.0	I	S	1.7	I	S	1.7	I	S	1.7
	50 HP & OVER	I	S	1.0	I	S	1.0	I	S	1.7	I	S	2.5	I	S	2.5
ROOF VENTILATORS																
ABOVE OCCUPIED AREAS:																
5 HP & OVER		---	---	---	CB	S	1.0	CB	S	1.0	CB	S	1.0	CB	S	1.0
CENTRIFUGAL BLOWERS																
UP TO 50 HP:																
UP TO 200 RPM		B	N	0.3	B	S	2.5	B	S	2.5	B	S	3.5	B	S	3.5
201 - 300 RPM		B	N	0.3	B	S	1.7	B	S	2.5	B	S	2.5	B	S	3.5
301 - 500 RPM		B	N	0.3	B	S	1.7	B	S	1.7	B	S	2.5	B	S	3.5
501 RPM & OVER		B	N	0.3	B	S	1.0	B	S	1.0	B	S	1.7	B	S	2.5
60 HP & OVER:																
UP TO 300 RPM		B	S	1.7	I	S	2.5	I	S	3.5	I	S	3.5	I	S	3.5
301 - 500 RPM		B	S	1.7	I	S	1.7	I	S	2.5	I	S	3.5	I	S	3.5
501 RPM & OVER		B	S	1.0	I	S	1.7	I	S	1.7	I	S	2.5	I	S	2.5

EQUIPMENT	ON GRADE			20FT FLOOR SPAN			30FT FLOOR SPAN			40FT FLOOR SPAN			50FT FLOOR SPAN		
	BASE TYPE	ISOL TYPE	MIN DEFL	BASE TYPE	ISOL TYPE	MIN DEFL	BASE TYPE	ISOL TYPE	MIN DEFL	BASE TYPE	ISOL TYPE	MIN DEFL	BASE TYPE	ISOL TYPE	MIN DEFL
COOLING TOWERS															
UP TO 500 RPM	---	---	---	---	SP	1.0	---	SP	1.7	---	SP	2.5	---	SP	3.5
501 RPM & OVER	---	---	---	---	SP	1.0	---	SP	1.0	---	SP	1.7	---	SP	2.5
INTERNAL COMBUSTION ENGINES															
UP TO 25 HP	I	N	0.3	I	N	0.3	I	S	1.7	I	S	2.5	I	S	2.5
30 THRU 100 HP	I	N	0.3	I	N	1.7	I	S	2.5	I	S	3.5	I	S	3.5
125 HP & OVER	I	N	0.3	I	N	2.5	I	S	3.5	I	S	4.5	I	S	4.5
AIR HANDLING UNIT PACKAGES															
SUSPENDED:															
UP THRU 5 HP	---	---	---	---	H	1.0	---	H	1.0	---	H	1.0	---	H	1.0
7-1/2 HP & OVER:															
UP TO 500 RPM	---	---	---	---	H, THR	1.7	---	H, THR	1.7	---	H, THR	1.7	---	H, THR	1.7
501 RPM & OVER	---	---	---	---	H, THR	1.0	---	H, THR	1.0	---	H, THR	1.7	---	H, THR	1.7
FLOOR MOUNTED:															
UP THRU 5 HP	---	D	---	---	S	1.0	---	S	1.0	---	S	1.0	---	S	1.0
7-1/2 HP & OVER:															
UP TO 500 RPM	---	D	---	R	S, THR	1.7	R	S, THR	1.7	R	S, THR	1.7	R	S, THR	1.7
501 RPM & OVER	---	D	---	---	S, THR	1.0	---	S, THR	1.0	R	S, THR	1.7	R	S, THR	1.7

EQUIPMENT	ON GRADE			20FT FLOOR SPAN			30FT FLOOR SPAN			40FT FLOOR SPAN			50FT FLOOR SPAN		
	BASE TYPE	ISOL TYPE	MIN DEFL	BASE TYPE	ISOL TYPE	MIN DEFL	BASE TYPE	ISOL TYPE	MIN DEFL	BASE TYPE	ISOL TYPE	MIN DEFL	BASE TYPE	ISOL TYPE	MIN DEFL
IN-LINE CENTRIFUGAL AND VANE AXIAL FANS, FLOOR MOUNTED: (APR 9)															
UP THRU 50 HP:															
UP TO 300 RPM	---	D	---	R	S	2.5	R	S	2.5	R	S	2.5	R	S	3.5
301 - 500 RPM	---	D	---	R	S	1.7	R	S	1.7	R	S	2.5	R	S	2.5
501 - & OVER	---	D	---	---	S	1.0	---	S	1.0	R	S	1.7	R	S	2.5
60 HP AND OVER:															
301 - 500 RPM	R	S	1.0	R	S	1.7	R	S	1.7	R	S	2.5	R	S	3.5
501 RPM & OVER	R	S	1.0	R	S	1.7	R	S	1.7	R	S	1.7	R	S	2.5

NOTES:

1. Refer to specification Section 15200 for isolators and symbols. Edit to suit where isolator, other than those shown, are used, such as for seismic restraints and position limit stops.
2. For suspended floors lighter than 100 mm (4 inch) thick concrete, select deflection requirements from next higher span.
3. For separate chiller building on grade, pump isolators may be omitted.
4. Direct bolt fire pumps to concrete base. Provide pads (D) for domestic water booster pump package.
5. For projects in seismic areas, use only SS & DS type isolators and snubbers.
6. Isolators not required where cooling tower is located on grade or on roof over mechanical room.
7. Floor mounted (APR 1): use "B" type in lieu of "R" type base.
8. Suspended: use "H" isolators of same deflection as floor mounted.

5.4 CLIMATIC CONDITIONS

Location	Weather Station	Latitude	Elevation	Col. 1a 0.4%		Col. 1b 99.6%		Col. 2a 1%		Col. 2b 99%		Col. 3 Wet Bulb		Annual Extreme Daily-Mean Db	
				Temperatures											
				Summer		Winter		Summer		Winter		0.4%	1%	Maximum	Minimum
				Db	Wb	Db		Db	Wb	Db					
ALABAMA															
Birmingham	Birmingham AP	33	630	95	76	18	93	76	23	78	77	98	9		
Montgomery	Montgomery AP	32	203	95	76	26	93	76	30	79	79	98	15		
Tuscaloosa	Tuscaloosa AP	33	171	95	77	20	99	77	24	80	79	99	11		
Tuskegee*	Tuskegee AP	32	195	96	79	22	95	79	22	-	-	-	-		
ALASKA															
Anchorage	Anchorage AP	61	131	71	59	-14	68	57	-9	60	58	77	-18		
ARIZONA															
Phoenix	Phoenix AP	33	1106	110	70	34	108	70	37	76	75	114	30		
Prescott	Prescott AP	34	5043	94	60	15	91	60	20	67	66	98	7		
Tucson	Tucson AP	32	2556	104	65	31	102	65	34	72	71	108	25		
ARKANSAS															
Fayetteville	Fayetteville AP	36	1250	95	75	6	93	75	13	78	77	100	-1		

Location	Weather Station	Latitude	Elevation	Col. 1a 0.4%		Col. 1b 99.6%		Col. 2a 1%		Col. 2b 99%		Col. 3 Wet Bulb		Annual Extreme Daily-Mean Db	
				Temperatures											
				Summer		Winter		Summer		Winter		0.4%	1%	Maximum	Minimum
				Db	Wb	Db	Db	Wb	Db						
Little Rock	Little Rock AFB	34	312	97	77	16	95	77	21	80	79	101	10		
N. Little Rock	Little Rock AFB	34	312	97	77	16	95	77	21	80	79	101	10		
CALIFORNIA															
Fresno	Fresno AP	36	328	103	71	30	101	70	32	73	71	107	26		
Livermore*	Livermore	37	545	100	71	24	97	70	24	-	-	-	-		
Loma Linda	Riverside-March AFB	33	1539	101	68	34	98	68	36	72	71	107	29		
Long Beach	Long Beach AP	33	39	92	67	40	88	67	43	71	70	102	35		
Los Angeles	Los Angeles Co	34	105	85	64	43	81	64	45	70	69	97	38		
Martinez*	Concord	38	195	100	7	24	97	70	24	-	-	-	-		
Palo Alto	San Jose AP	37	56	93	67	35	89	66	38	70	68	101	27		
Menlo Park	San Jose AP	37	56	93	67	35	89	66	38	70	68	101	27		
San Diego	San Diego AP	32	30	85	67	46	81	67	46	73	71	95	39		
San Francisco	San Francisco AP	37	16	83	63	37	78	62	39	64	63	94	33		
Sepulveda	Burbank AP	34	774	95	71	39	91	70	41	74	72	106	33		

Location	Weather Station	Latitude	Elevation	Col. 1a 0.4%		Col. 1b 99.6%		Col. 2a 1%		Col. 2b 99%		Col. 3 Wet Bulb		Annual Extreme Daily-Mean Db	
				Temperatures										Maximum	Minimum
				Summer		Winter		Summer		Winter		0.4%	1%		
				Db	Wb	Db		Db	Wb	Db					
COLORADO															
Denver	Denver AP	39	5331	93	60	-3	90	54	3	65	63	97	-11		
Ft. Lyon*	La Junta AP	38	4188	100	72	-3	98	70	-3	-	-	-	-		
Grand Junction	Grand Junction AP	39	4839	96	61	2	94	60	7	65	64	100	-3		
CONNECTICUT															
Newington	Hartford/ Brainard Field	41	20	91	73	2	88	72	6	76	74	97	-6		
West Haven*	West Haven AP	41	6	88	76	3	84	76	3	-	-	-	-		
DELAWARE															
Wilmington	Wilmington AP	39	79	91	75	10	89	74	14	78	76	96	3		
DISTRICT OF COLUMBIA															
Washington	National AP	38	66	95	76	15	92	76	20	79	78	99	8		
FLORIDA															
Bay Pines	St. Petersburg	28	10	94	80	43	93	79	47	82	82	97	35		
Coral Gables	Miami AP	25	13	91	77	46	90	77	50	80	79	94	39		
Gainesville	Gainesville AP	29	151	95	80	30	93	79	33	80	79	97	21		

Location	Weather Station	Latitude	Elevation	Col. 1a 0.4%		Col. 1b 99.6%		Col. 2a 1%		Col. 2b 99%		Col. 3 Wet Bulb		Annual Extreme Daily-Mean Db	
				Temperatures											
				Summer		Winter		Summer		Winter		0.4%	1%	Maximum	Minimum
				Db	Wb	Db	Db	Wb	Db						
Lake City	Gainesville AP	29	151	95	80	30	93	79	33	80	79	97	21		
Miami	Miami AP	25	13	91	77	46	90	77	50	80	79	94	39		
Orlando	Orlando	28	105	94	76	37	93	76	42	79	79	96	29		
Tampa	Tampa AP	28	10	92	77	36	91	77	40	80	79	95	29		
GEORGIA															
Atlanta	Atlanta AP	33	1033	93	75	18	91	74	23	77	76	96	9		
Augusta	Augusta AP	33	148	96	76	21	94	76	25	78	78	100	13		
Dublin*	Dublin AP	32	215	96	79	21	93	78	21	-	-	-	-		
Decatur	Atlanta AP	33	1033	93	75	18	91	74	23	77	76	96	9		
HAWAII															
Honolulu	Honolulu AP	21	16	89	73	61	88	73	63	76	75	91	58		
IDAHO															
Boise	Boise AP	43	2817	96	63	3	94	63	3	66	64	98	-11		
ILLINOIS															
Chicago W. Side	Meigs Field	41	623	92	74	-3	89	73	3	77	76	97	-10		
Chicago Lakeside	Meigs Field	41	623	92	74	-3	89	73	3	77	76	97	-10		

Location	Weather Station	Latitude	Elevation	Col. 1a 0.4%		Col. 1b 99.6%		Col. 2a 1%		Col. 2b 99%		Col. 3 Wet Bulb		Annual Extreme Daily-Mean Db	
				Temperatures											
				Summer		Winter		Summer		Winter		0.4%	1%	Maximum	Minimum
				Db	Wb	Db	Db	Wb	Db	Db					
Danville*	Danville	40	558	93	78	-3	90	77	-4	-	-	-	-		
Downey*	Waukegan	42	680	92	78	-6	89	76	-6	-	-	-	-		
Hines	Meigs Field	41	623	92	74	-3	89	73	3	77	76	97	-10		
Marion*	Mt. Vernon	-	-	95	79	0	92	78	0	-	-	-	-		
INDIANA															
Ft Wayne	Ft. Wayne AP	41	827	90	74	-4	88	73	2	77	75	95	-11		
Indianapolis	Indianapolis AP	39	807	91	75	-3	88	74	3	78	77	94	-10		
Marion*	Marion	40	791	91	77	-4	90	75	-4	-	-	-	-		
IOWA															
Des Moines	Des Moines AP	41	965	93	76	-9	90	74	-4	78	76	98	-15		
Iowa City*	Iowa City	41	645	92	80	-11	89	78	-11	-	-	-	-		
Knoxville	Des Moines AP	41	965	93	76	-9	90	74	-4	78	76	98	-15		
KANSAS															
Leavenworth	Kansas City, MO AP	39	1024	96	75	-1	93	75	4	78	77	100	-7		
Topeka	Topeka AP	39	886	96	75	-2	93	75	4	79	78	100	-8		
Wichita	Wichita AP	37	1339	100	73	2	97	73	8	77	76	105	-4		

Location	Weather Station	Latitude	Elevation	Col. 1a 0.4%		Col. 1b 99.6%		Col. 2a 1%		Col. 2b 99%		Col. 3 Wet Bulb		Annual Extreme Daily-Mean Db	
				Temperatures										Maximum	Minimum
				Summer		Winter		Summer		Winter		0.4%	1%		
				Db	Wb	Db		Db	Wb	Db					
KENTUCKY															
Lexington	Lexington AP	38	988	91	74	4	89	73	10	77	75	94	-4		
Louisville	Louisville AP	38	489	93	76	6	90	75	12	78	77	96	-1		
LOUISIANA															
Alexandria	England AFB	31	89	95	78	27	94	78	30	81	80	98	20		
New Orleans	New Orleans AP	30	10	93	78	35	92	78	39	81	80	94	21		
Shreveport	Shreveport AP	32	259	97	77	22	95	77	26	79	79	99	16		
MAINE															
Togus	Augusta AP	44	351	87	71	-3	84	69	1	73	71	93	-16		
MARYLAND															
Baltimore	Baltimore AP	39	154	93	75	11	91	74	15	78	76	97	4		
Perry Point	Baltimore AP	39	154	93	75	11	91	74	15	78	76	97	4		
MASSACHUSETTS															
Bedford	Boston AP	42	30	91	73	7	87	71	12	75	74	96	0		
Boston	Boston AP	42	30	91	73	7	87	71	12	75	74	96	0		
Brockton*	Taunton	41	20	89	75	5	86	74	5	-	-	-	-		
North Hampton*	Springfield/Westover AFB	42	247	90	75	-5	87	73	-5	-	-	-	-		

Location	Weather Station	Latitude	Elevation	Col. 1a 0.4%		Col. 1b 99.6%		Col. 2a 1%		Col. 2b 99%		Col. 3 Wet Bulb		Annual Extreme Daily-Mean Db	
				Temperatures											
				Summer		Winter		Summer		Winter		0.4%	1%	Maximum	Minimum
				Db	Wb	Db	Db	Wb	Db						
West Roxbury	Boston AP	42	30	91	73	7	87	71	12	75	74	96	0		
MICHIGAN															
Ann Arbor*	Ypsilanti	42	777	92	75	1	89	74	1	-	-	-	-		
Allen Park	Detroit Metro CAP	42	663	90	73	0	87	72	5	76	74	95	-7		
Battle Creek*	Battle Creek AP	42	939	92	76	1	88	74	1	-	-	-	-		
Detroit	Detroit Metro CAP	42	663	90	73	0	87	72	3	76	74	95	-7		
Iron Mountain*	Escanaba	45	594	87	73	-11	83	71	-11	-	-	-	-		
Saginaw	Saginaw AP	43	669	90	74	0	87	72	4	77	75	96	-6		
MINNESOTA															
Minneapolis	Minneapolis AP	44	837	91	73	-16	88	71	-11	76	74	97	-22		
St. Cloud	St. Cloud AP	45	1024	91	72	-20	88	71	-14	76	74	95	-27		
MISSISSIPPI															
Jackson	Jackson AP	32	331	95	77	21	91	78	25	80	79	98	14		
Biloxi	Keesler AFB	30	33	92	79	31	91	78	35	81	80	97	23		
Gulfport	Keesler AFB	30	33	92	79	31	91	78	35	81	80	97	23		

Location	Weather Station	Latitude	Elevation	Col. 1a 0.4%		Col. 1b 99.6%		Col. 2a 1%		Col. 2b 99%		Col. 3 Wet Bulb		Annual Extreme Daily-Mean Db	
				Temperatures											
				Summer		Winter		Summer		Winter		0.4%	1%	Maximum	Minimum
				Db	Wb	Db	Db	Wb	Db	Db					
MISSOURI															
Columbia	Columbia AP	39	899	95	77	-1	94	77	5	78	77	99	-8		
Kansas City	Kansas City AP	39	1024	96	75	-1	93	75	4	78	77	100	7		
Poplar Bluff	Poplar Bluff	36	479	95	77	8	92	76	13	80	78	101	2		
St. Louis (JBO)	St. Louis AP	38	564	95	76	2	93	75	8	79	78	99	-5		
MONTANA															
Ft. Harrison	Helena AP	46	3898	90	60	-18	87	59	-10	63	61	96	-24		
Miles City	Miles City AP	46	2628	97	66	-19	93	65	-13	69	67	102	-25		
NEBRASKA															
Grand Island	Grand Island AP	41	1857	97	72	-8	93	72	-2	76	74	102	-14		
Lincoln	Lincoln CO	40	1188	97	74	-7	94	74	-2	78	76	103	-11		
Omaha	Eppley Airfield	41	981	95	75	-7	92	75	-2	78	77	100	-14		
NEVADA															
Reno	Reno AP	39	4400	95	61	8	92	60	13	63	62	99	1		
NEW HAMPSHIRE															
Manchester*	Grenier AFB	43	253	91	75	-8	88	74	-8	-	-	-	-		

Location	Weather Station	Latitude	Elevation	Col. 1a 0.4%		Col. 1b 99.6%		Col. 2a 1%		Col. 2b 99%		Col. 3 Wet Bulb		Annual Extreme Daily-Mean Db	
				Temperatures										Maximum	Minimum
				Summer		Winter		Summer		Winter		0.4%	1%		
				Db	Wb	Db		Db	Wb	Db					
NEW JERSEY															
East Orange	Newark AP	40	30	93	74	10	90	73	14	77	76	98	4		
Lyons*	New Brunswick	40	86	92	77	6	89	76	6	-	-	-	-		
NEW MEXICO															
Albuquerque	Albuquerque AP	35	5315	96	60	13	93	60	18	65	64	100	6		
NEW YORK															
Albany	Albany AP	42	292	90	71	-7	86	70	-2	74	73	95	-18		
Batavia*	Batavia	43	900	90	75	1	87	73	1	-	-	-	-		
Bath*	Hornell	42	1325	88	74	-4	85	73	-4	-	-	-	-		
Bronx	NYC/John F. Kennedy Int. AP	40	23	91	74	11	88	72	15	76	75	96	6		
Brooklyn	NYC/ John F. Kennedy Int. AP	40	23	91	74	11	88	72	15	76	75	96	6		
Buffalo	Buffalo	43	705	86	70	2	84	69	5	74	72	91	-6		
Canandaigua*	Geneva	42	590	90	75	-3	87	73	-3	-	-	-	-		
Castle Point	Poughkeepsie	41	167	92	75	2	88	72	6	76	75	96	-8		

Location	Weather Station	Latitude	Elevation	Col. 1a 0.4%		Col. 1b 99.6%		Col. 2a 1%		Col. 2b 99%		Col. 3 Wet Bulb		Annual Extreme Daily-Mean Db	
				Temperatures											
				Summer		Winter		Summer		Winter		0.4%	1%	Maximum	Minimum
				Db	Wb	Db	Db	Wb	Db	Db					
Montrose*	Newberg-Stewart AFB	41	460	90	76	-1	88	74	-1	-	-	-	-		
New York City	NYC/John F. Kennedy Int. AP	40	23	91	74	11	88	72	15	76	75	96	6		
Northport*	Suffolk Co. AFB	40	57	86	76	7	83	74	7	-	-	-	-		
Syracuse	Syracuse AP	43	407	88	72	-3	85	71	2	75	73	93	-13		
St. Albans	NYC/John F. Kennedy Int. AP	40	23	91	74	11	88	72	15	76	75	96	6		
NORTH CAROLINA															
Durham	Durham	36	440	93	76	16	90	75	20	78	77	96	9		
Fayetteville	Fort Bragg	35	243	96	77	22	94	76	27	79	78	100	15		
Asheville (Oteen)	Asheville AP	35	2169	88	72	11	85	71	16	75	73	91	3		
Salisbury	Winston-Salem AP	36	971	92	74	18	89	74	23	77	76	96	8		
NORTH DAKOTA															
Fargo	Fargo AP	46	899	91	71	-22	88	70	-17	75	73	98	-27		

Location	Weather Station	Latitude	Elevation	Col. 1a 0.4%		Col. 1b 99.6%		Col. 2a 1%		Col. 2b 99%		Col. 3 Wet Bulb		Annual Extreme Daily-Mean Db	
				Temperatures										Maximum	Minimum
				Summer		Winter		Summer		Winter		0.4%	1%		
				Db	Wb	Db		Db	Wb	Db					
OHIO															
Brecksville	Cleveland AP	41	804	89	73	1	86	72	6	76	74	93	-6		
Chillicothe*	Chillicothe	39	638	95	78	0	92	76	0	-	-	-	-		
Cincinnati	Lunken Field	39	482	93	74	5	90	75	12	77	76	96	-3		
Cleveland	Cleveland AP	41	804	89	73	1	86	72	6	76	74	93	-6		
Dayton	Dayton AP	39	1004	90	74	-1	88	73	5	76	75	95	-8		
OKLAHOMA															
Muskogee*	Muskogee	35	610	101	79	10	98	78	10	-	-	-	-		
Oklahoma City	Oklahoma City AP	35	1302	99	74	9	96	74	15	77	76	103	4		
OREGON															
Portland	Portland CO	45	39	90	67	22	86	66	27	69	67	99	18		
Roseburg*	Roseburg AP	43	505	93	69	18	90	67	18	-	-	-	-		
White City	Medford AP	42	1329	98	67	21	95	66	24	69	67	104	15		
PENNSYLVANIA															
Altoona	Altoona CO	40	1503	89	72	5	86	70	10	74	72	92	-5		
Butler*	Butler	40	1100	90	75	1	87	74	1	-	-	-	-		
Coatesville*	New Castle	41	825	91	75	2	88	74	2	-	-	-	-		

Location	Weather Station	Latitude	Elevation	Col. 1a 0.4%		Col. 1b 99.6%		Col. 2a 1%		Col. 2b 99%		Col. 3 Wet Bulb		Annual Extreme Daily-Mean Db	
				Temperatures											
				Summer		Winter		Summer		Winter		0.4%	1%	Maximum	Minimum
				Db	Wb	Db	Db	Wb	Db	Db					
Erie	Erie AP	42	738	85	72	2	83	70	7	74	73	90	-4		
Lebanon	Harrisburg AP	40	308	92	74	9	89	73	13	77	76	97	2		
Philadelphia	Philadelphia AP	39	30	92	75	11	89	74	15	78	77	96	5		
Pittsburgh	Pittsburgh AP	40	1224	89	72	2	86	70	7	74	73	93	-6		
Wilkes-Barre	Scranton/Wilkes-Barre	41	948	88	71	2	85	70	7	74	73	92	-5		
PUERTO RICO															
San Juan	San Juan	18	62	92	77	69	90	78	69	81	80	94	56		
RHODE ISLAND															
Providence	Providence AP	41	62	89	73	5	86	71	10	76	74	95	-2		
SOUTH CAROLINA															
Charleston	Charleston AP	32	49	94	78	25	92	77	28	80	79	98	18		
Columbia	Columbia AP	34	226	96	76	21	94	75	24	78	77	100	13		
SOUTH DAKOTA															
Ft. Meade	Rapid City AP	44	3169	95	65	-11	91	65	-5	70	68	102	-17		
Hot Springs	Rapid City AP	44	3169	95	65	-11	91	65	-5	70	68	102	-17		
Sioux Falls	Sioux Falls AP	43	1427	94	73	-16	90	72	-11	76	75	100	-23		

Location	Weather Station	Latitude	Elevation	Col. 1a 0.4%		Col. 1b 99.6%		Col. 2a 1%		Col. 2b 99%		Col. 3 Wet Bulb		Annual Extreme Daily-Mean Db	
				Temperatures										Maximum	Minimum
				Summer		Winter		Summer		Winter		0.4%	1%		
				Db	Wb	Db		Db	Wb	Db					
TENNESSEE															
Memphis	Memphis AP	35	285	96	78	16	94	77	21	80	79	99	9		
Mountain Home	Bristol-Tri-City AP	36	1519	89	72	9	87	72	14	75	74	92	-1		
Murfreesboro*	Murfreesboro AP	35	608	97	78	9	94	77	9	-	-	-	-		
Nashville	Nashville AP	36	591	94	76	10	92	75	16	78	77	97	1		
TEXAS															
Amarillo	Amarillo AP	35	3606	96	71	6	97	71	12	71	70	100	-1		
Big Spring*	Big Spring AP	32	2537	100	74	16	97	73	16	-	-	-	-		
Bonham*	Sherman-Perrin AFB	33	763	100	78	15	98	77	15	-	-	-	-		
Dallas	Dallas AP	32	597	100	74	17	98	74	24	78	77	103	14		
Houston	Houston CO	29	108	96	77	27	94	77	31	80	79	98	22		
Kerrville	San Antonio AP	29	794	98	73	26	96	73	30	78	77	100	19		
Marlin	Waco AP	31	509	101	75	22	99	75	26	79	78	104	16		
San Antonio	San Antonio AP	29	794	98	73	26	96	73	30	78	77	100	19		
Temple*	Temple	31	675	100	78	22	99	77	22	-	-	-	-		

Location	Weather Station	Latitude	Elevation	Col. 1a 0.4%		Col. 1b 99.6%		Col. 2a 1%		Col. 2b 99%		Col. 3 Wet Bulb		Annual Extreme Daily-Mean Db	
				Temperatures											
				Summer		Winter		Summer		Winter		0.4%	1%	Maximum	Minimum
				Db	Wb	Db	Db	Wb	Db	Db					
Waco	Waco AP	31	509	101	75	22	99	75	26	79	78	104	16		
UTAH															
Salt Lake City	Salt Lake City AP	40	4226	96	62	6	94	62	11	66	65	100	-3		
VERMONT															
White River Junction	Barre	44	1165	85	70	-10	83	68	-6	72	70	91	-18		
VIRGINIA															
Hampton	Norfolk AP	36	30	93	77	20	91	76	24	79	77	97	14		
Richmond	Richmond AP	37	177	94	76	14	92	75	18	79	78	98	6		
Salem	Roanoke AP	37	1175	92	73	12	89	72	17	75	74	96	4		
WASHINGTON															
American Lake	Olympia AP	47	200	87	67	18	83	65	23	68	66	94	10		
Seattle	Seattle Int. AP	47	449	85	65	23	81	64	28	66	65	92	19		
Spokane	Fairchild AFB	47	2461	92	62	1	89	61	7	65	63	98	-7		
Vancouver	Portland Ore. CO	45	39	90	67	22	86	66	27	69	67	99	18		
Walla Walla	Walla Walla	46	1204	98	66	4	95	65	12	68	67	105	1		

Location	Weather Station	Latitude	Elevation	Col. 1a 0.4%		Col. 1b 99.6%		Col. 2a 1%		Col. 2b 99%		Col. 3 Wet Bulb		Annual Extreme Daily-Mean Db	
				Temperatures										Maximum	Minimum
				Summer		Winter		Summer		Winter		0.4%	1%		
				Db	Wb	Db	Db	Wb	Db	Db					
WEST VIRGINIA															
Beckley*	Beckley	37	2330	83	73	-2	81	71	-2	-	-	-	-		
Clarksburg*	Clarksburg	39	977	92	76	6	90	75	6	-	-	-	-		
Huntington	Huntington CO	38	837	91	74	6	89	73	11	77	76	94	-2		
Martinsburg	Martinsburg AP	39	558	94	74	8	91	73	14	77	75	99	-3		
WISCONSIN															
Madison	Madison AP	43	858	90	73	-11	87	72	-6	76	74	94	-18		
Tomah	La Crosse AP	43	663	91	74	-14	88	73	-6	77	75	97	-21		
Wood	Milwaukee AP	43	692	89	74	-7	86	72	-2	76	74	95	-12		
WYOMING															
Cheyenne	Warren AFB	41	6142	87	58	-7	85	57	0	62	61	92	-15		
Sheridan	Sheridan AP	44	3967	93	63	-22	93	63	-13	66	64	99	-22		

NOTES:

1. The CLIMATIC CONDITIONS table data is based on the 1997 ASHRAE Handbook of Fundamentals and the Department of Defense Engineering Weather Data, an asterisk identifies 1978. Use column 1a and 1b for design of New Hospitals, NHCU, Outpatient Clinics and other buildings for the purpose of patient care. Use column 2a and 2b for design of Regional Offices and Laundry type buildings.

*Not listed by ASHRAE.

INDEX OF HVAC CRITERIA

AIR HANDLING UNITS	2.3.1
Access Sections	2.3.1.3
Blow through type	2.3.1.2
Casing	2.3.1.3
Central Humidifier	2.3.3
Coils	2.3.1.5
Dedicated Air Handling Units	2.2.10
Drains	2.3.5
Draw - through type	2.3.1.1
Duct Lining	2.3.4
Exceptions to Dedicated Air Handling Units	2.2.11
Fans	2.3.1.4
Filters	2.3.2, Table 2-1
Sound Attenuators	2.3.4
Variable Speed motor controllers	2.3.1.4
ALL-AIR SYSTEMS	2.2
Air Circulation	2.2.7
Dual Duct System	2.2.4
Functional Needs of Spaces	2.2.9
Interior Rooms	2.2.2
System Zoning	2.2.6
Terminal Reheat System	2.2.3
Variable Air Volume (VAV) Systems	2.4
AIR PRESSURE RELATIONSHIP	1.3.7
AIR DISTRIBUTION	1.3.15.1(h)
AMBULATORY CARE	3.1
AMBULANCE ENTRANCES	3.2
ANIMAL RESEARCH FACILITY	3.3
Animal Operating Rooms	3.3.3
Cage Washers	3.3.4
AUDIOLOGY SOUND SUITES	3.4
AUDITORIUMS AND THEATERS	3.5
BONE MARROW TRANSPLANT (BMT)	3.6
BIOMEDICAL INSTRUMENT REPAIR SHOP	4.2
CALCULATIONS, ANALYSIS AND REVIEW SUBMITTALS	1.5
Calculations	1.5.1
Economic Analysis	1.5.2
HVAC Calculations for Higher Elevations	1.6
Review Submittals	1.5.3
CENTRAL CHILLED WATER FLOW DIAGRAM	2.12.3
CHILLED WATER SYSTEM	2.12.2
Capacity of Chilled Water System	1.3.15.2(a)
Chiller Performance	2.12.2.3
Maximum Chiller Capacity	2.12.2.2
Number of Chillers	2.12.2.1
Primary/Secondary Arrangement	2.12.2.5(3)
Reserve Space Requirement for New Construction	2.12.2.5
Standby Equipment	2.12.2.4
Secondary Distribution Interface Flow Diagram	2.12.4

Secondary/Tertiary Distribution Interface Blow Diagram	2.12.5
Temperature Differential	2.12.2.5(5)
Tertiary Arrangement	2.12.2.5(b)(4)
CLIMATIC CONDITIONS	1.1.4, 5.4
COILS	2.3.1.5
Cooling Coils	2.3.1.5(a)
Preheat Coils	2.3.1.5(b)
Reheat Coils	2.3.1.5(c)
COMPUTER ROOMS	3.8
CONNECTING CORRIDORS HVAC	1.3.11
CONTRACT DRAWINGS	1.4
Ductwork Drawings	1.4.5
Piping Drawings	1.4.4
Schematic Diagram for Chilled Water	2.12.13
COOLING TOWERS	2.12.11
CRITERIA UNIQUE TO VA	1.1
C T SCANNER	3.7
INDOOR DESIGN CONDITIONS	3.17
DENTAL PROSTHETIC LABORATORIES	3.9
DOCUMENTATION REQUIREMENTS	2.12.13
Schematic Drawings for chilled Water	2.12.13.1
DESIGN FEATURES	1.9.3
DUCT LINING	1.3.15.4
DUCTED RETURN/EXHAUST	2.2.7
ETHYLENE GLYCOL-WATER SYSTEMS (EGWS)	
Effect of EGWS on Pump and Piping Systems	2.8
EMERGENCY POWER REQUIREMENTS FOR HVAC EQUIPMENT	2.16
ENERGY CONSERVATION	1.9
ENERGY CONSERVATION CERTIFICATION REQUIREMENTS	1.1.7
ENGINEERING ECONOMIC ANALYSIS	1.1.6
ENTRANCES	1.3.9
EQUIPMENT LOCATION AND INSTALLATION	1.7
EQUIPMENT SCHEDULES	1.4.3
EQUIPMENT SIZING CRITERIA	1.3.15
EXHAUST AIR SYSTEMS	
Animal Research Area	2.11.11
Battery Charging Room Exhaust	2.11.10
Biomedical Instrument Repair Shop	4.2
Compliance Requirements for NFPA 90A	2.11.2
Elevator Machine Rooms	4.3

Emergency Generator Rooms	4.4
Flammable and Combustible Liquid Storage	4.5
General Exhaust Systems	2.11.1
Grease Producing Equipment	3.12.7.1
Hot Vapor Producing Equipment	3.12.7.2
Isolation Suite Exhaust Systems	2.11.6
Kitchen Exhaust Systems	2.11.7
Location of Exhaust Air Outlets	1.8
Maintenance Garages	2.11.12
Minimum Exhaust Air Requirements	Table 1-4
Nurse Server Cabinet Exhaust	2.11.8
Radioactive Iodine	4.7
Reagent Grade Water Treatment Rooms	4.6
Special Exhaust System	2.11.2.2
Transformer Rooms	4.9
Trash Collection Areas	4.10
Wet Exhaust	3.12.8
Xenon Gas	4.12
EXISTING RADIATORS	1.10.3
FAN COIL UNITS	2.5
Installation Restrictions	2.5.2
Interior Rooms	2.5.3
FILTERS	2.3.2
Air Filters	2.3.2
Air Filter Efficiency	Table 2-1
Chilled Water Filter	2.12.2.5(6)
BALANCING DAMPERS	1.4.5.4
FIRE DAMPERS	1.4.5.7
SMOKE DAMPERS	1.4.5.7
FLASH TANKS	2.9.8.3
FREEZE PROTECTION-Chiller Water System	2.12.10
FREEZE PROTECTION-Condensed Water system	2.12.11
GRAPHIC STANDARDS	1.1.3
HEATING SYSTEMS (HYDRONIC)	2.7.4.5
Controls	2.7.5
Deletion of Perimeter Heating	2.7.3
Perimeter Heating	2.7.2
Reheat and Miscellaneous Heating	2.7.4.4.2
HEATING SYSTEMS (STEAM)	2.7.5
Applications	2.7.5.2
Controls	2.7.5.4
HEATING SYSTEM (ELECTRIC)	2.7.6
Application	2.7.6.2
Controls	2.7.6.4
Equipment type	2.7.6.3
HEATING SYSTEM (GAS)	2.7.7
Controls	2.7.7.3
Equipment Type	2.7.7.2
General	2.7.7.1
INDOOR DESIGN CONDITIONS	Table 1-1
INSULATION	
Pre-insulated Chilled Water Piping	2.12.12
INTENSIVE CARE UNITS (ICU's)	3.10

ISOLATION ROOMS	3.11
Isolation Room Exhaust System	2.11.6
APPLICABLE DESIGN AND CONSTRUCTION	
PROCEDURES AND REFERENCE DOCUMENTS INDEX	5.1
KITCHENS (MAIN) AND KITCHENS FOR LARGE CAFETERIAL	3.12
LABORATORY HOOD EXHAUST SYSTEMS	2.11.3
Automatic Air Flow Control	2.11.3.1(f)
Autopsy and Morgue Exhaust Systems	2.11.4
Class II Biological Safety Cabinets	2.11.3.4.1
Dedicated Exhaust System	2.11.3.1
Dental Prosthetic Laboratory	3.9
Dry Laboratories	3.12.6
Duct Velocity	2.11.3.1(c)
Emergency Power Requirements	2.16
ETO Sterilizer Exhaust System	2.11.5
H12, Biological Safety Cabinets	2.11.3.4
H14, Perchloric Acid Hoods	2.11.3.5
H3 Radioisotope Hoods	2.11.3.2
H7/H13 Fume Hoods	2.11.3.3
Noise Criteria	2.11.3.1(a)
Orthotic/Prosthetic Lab Exhaust System	2.11.9
LOUVERS	1.8.4
LIFE CYCLE COST	1.1.6
Waiver of Life Cycle Cost for Existing Buildings	1.10.1.2
LINEAR ACCELERATORS	3.15
MNOR O.R. (TRAUMA ROOM)	3.1.2
MOTOR VOLTAGES	Table 1-5
MEDICAL MEDIA SERVICE (MMS)	3.16
MRI	3.17
NOISE CRITERIA	1.3.12
NON-AIR CONDITIONED AREAS	1.3.8
OUTDOOR AIR REQUIREMENTS	1.3.5
100 percent Outdoor Areas	1.3.5.1
Non-100 percent Outdoor Areas	1.3.5.2
LOCATION OF OUTSIDE AIR INTAKES	1.8
PIPING	
Pipe Sizing Criteria	1.3.15.3
Preheat Coils	2.3.1.5(b)
Pre-insulated Chilled Water Piping	2.12.12
Pressure Reducing Stations	2.9.4
Pressure Reducing Valves	2.9.4
Psychiatric Areas	3.17
Steam Condensate Piping	2.9.8
Steam Piping	2.9.5
Steam Vent Lines	2.9.9
RADIANT CEILING PANEL SYSTEM	2.6
REFRIGERATION SYSTEMS FOR AIR-CONDITIONING	2.12
System Type	2.12.1.1
System Selection	2.12.1.2
Refrigerant Selection	2.12.1.3

DX Refrigeration System	2.12.6
Refrigeration System for Surgery Suites	2.12.7
Refrigeration System for Animal Research	2.12.9.1.1
Refrigeration System for Linear Accelerators	2.12.9.1.1
Refrigeration System for MRI	2.12.9.1.2
Refrigeration System for Telephone Equipment Rooms	2.12.9.1.3
Refrigeration System for Elevator Machine Rooms	2.12.9.1.4
SCHEDULE OF TABLES FOR CHAPTERS 1 Through 4	5.2
SCOPE OF HVAC DESIGN	1.2
General	1.2.1
Drawing Requirements	1.2.2
Interdiscipline Coordination	1.2.3
SEISMIC REQUIREMENTS (HVAC)	2.15
Drawings	2.15.5
NUSIG	2.15.1, 2.15.3
Seismic Zone Factors "Z"	2.15.1
SMACNA	2.15.1.4
SHIELDED ROOMS	3.18
SMOKE AND FIRE PROTECTION	2.13
Atriums	2.13.2.6
Deletion of Smoke Detectors and Smoke Dampers	2.13.2.5.1
Elevator Shafts Smoke Venting	2.13.2.8
Locations not Requiring Smoke Dampers	2.13.3.7
Penetration of Fire and Smoke Barriers	2.13.3
Smoke and Fire Protection Control Diagram	2.13.4
SMOKE DETECTORS	1.4.5.6
SPD	3.20
Minimum Supply Air and Room Pressure Requirements	Table 3-4
STAIRS-EXTERIOR	1.3.10
STEAM DISTRIBUTION	2.9
Steam Generation	2.9.1
Outdoor Steam Distribution	2.9.2
Inside Steam Distribution	2.9.3
Steam Pressure Classification	Table 2-9
Steam Pressure Requirements for Equipment	Table 2-10
Pressure Reducing Valves and Pressure Reducing Stations	2.9.4
Steam Piping	2.9.5
STEAM GUN SET	2.9.6
STEAM TRAPS	2.9.7
Minimum Supply Air Requirements	Table 1-2
SUPPLY AIR REQUIREMENTS	1.3.4
SURGERY SUITE SYSTEMS	3.21
SURGERY UNITS	3.21
Existing Surgery Units	1.10.2
TABLE OF SELECTION GUIDE FOR VIBRATION ISOLATORS	5.3
TB CRITERIA	3.22
Indoor Design Conditions	Table 3-5
Supply Air Requirements	Table 3-6
Policy and Procedures	3.22.3
Reference Documents	3.22.2

Air Distribution	3.22.4.6
Negative Pressure Monitor	3.22.4.6(C)
Exhaust and Intake Outlets	3.22.5.3
TEMPERATURE CONTROLS	2.14
Engineering Control Center (ECC)	2.14.2
Input and Output points Schedule	2.14.2.3
Control Room	2.14.4
VARIABLE SPEED DRIVES	2.12.13.5
VAV SYSTEM	2.4
VENTILATION	2.10
Areas where mechanical cooling is not required	2.10.1
Occupied Areas	2.10.2
Unoccupied Areas	2.10.3
Minimum Ventilation Air Changes per Hour	Table 2-11
Trash Collection Areas	2.10.4
Elevator Machine Rooms	2.10.5
Heat Dissipation Data for Elevator Machine Rooms	Table 2-12
Emergency Generator Rooms	2.10.6
Transformer Rooms	2.10.7
Electric Closets	2.10.7
VIBRATION	
Criteria	1.3.13
Selection Guide	5.3
WALK IN REFRIGERATORS	4.11
Design Temperatures	Table 4-1
WATER TREATMENT	
Chilled Water	2.12.2.5(7)